

Stratford Central Secondary School

Avon Maitland
District School Board
Secondary Schools



Program & Course
Course Calendar
2017-2018

Table of Contents

School Philosophy	3
School Support Services and Resources	3
Student Responsibilities	5
Special Programs	6
Experiential Learning	8
Dual Credit Offerings at Conestoga, Fanshawe and Lambton Colleges	8
What does it cost?	9
What makes a student eligible?	9
How do I apply?	9
Ontario Youth Apprenticeship Program	9
Specialist High Skills Majors	10
Avon Maitland District E-Learning Centre (AMDEC)	10
What You Need to Graduate	11
The Arts	13
Business Studies	19
Canadian & World Studies	20
History	21
Law & Politics	23
Interdisciplinary Studies	24
Cooperative Education	24
Ontario Youth Apprenticeship Program	25
English	25
French Immersion	29
Guidance & Career Education	32
Health & Physical Education	32
Languages	35
Mathematics	37
Science	41
Social Sciences & Humanities	45
Special Education	48
Technological Studies	48
Apprenticeship Pathway	54
College Pathway	55
University Pathway	56
Workplace Pathway	57

SCSS Course Calendar 2017

By Kevin Mills - Principal

The Avon Maitland District School Board is committed to ensuring students have the opportunity to graduate secondary school in four years and to ensuring a variety of course offerings for our students. In order to achieve both goals efficiently students need to be registered full time in each semester. Students at Avon Maitland District School Board secondary schools will be required to register with a sufficient number of courses to be considered full time for each semester in which they attend our schools.

School Philosophy

At Stratford Central Secondary School, we are dedicated to providing a safe, welcoming and inclusive learning environment. The school provides opportunities for each student to be successful while encouraging responsibility, productivity, learning and a growth mindset.

Upon graduating, we are confident each of our graduates will have the necessary skills to meet the challenges beyond secondary school, as well as, exhibit positive citizenship and character within our society.

School Support Services and Resources

The Guidance Department at Stratford Central provides opportunities for students to become self-assured, independent, successful individuals by encouraging the use of our personal, academic and educational planning and career counselling services. Students always have access to career planning opportunities through computer programs. The department has the most recent calendars, videos and other materials from community colleges, universities and private schools. Each fall, an extensive schedule of liaison visits of the university and college representatives is available to students. The counsellors also provide information for the students to visit the campuses and tour the facilities. Students are assisted with the application procedure for university and/or college admission, for scholarships and bursaries and for financial aid. Students are encouraged to see their counsellor for any of these or any other services. The Guidance Department welcomes parents and guardians to speak with any of the counsellors concerning their child's needs or performance.

Student Fees

There will be no fees or cost charged to students to participate in the regular day school program. Fees may be charged where the student chooses to upgrade the material or where purchase of material is optional. Students enrolled in secondary schools in Avon Maitland District School Board can expect to be provided with the basic classroom learning resources that are required in order to complete the course expectations. It is recognized there may be optional resources that students may purchase to enhance their program; e.g. field trips, upgrading materials in courses such as construction, technology and visual arts. Students are expected to come to school ready and willing to participate actively in

their own learning. To that end, students are expected to bring materials with them for their own personal note-taking (e.g. pencils, pens, paper, binders).

Students are encouraged to purchase their school's student card by paying the student activity fee. The student card includes but is not limited to the benefit of participating in the co-instructional program and in the Student Council dances and activities. The fee may also be used to reduce the total cost of a student's yearbook. Students involved in co-instructional teams, groups and clubs will be made aware of any additional fundraising obligations or participation fees prior to making a commitment to participate.

Need Support? Programs Available

Students may access support through a variety of resources such as Guidance, noon hour help room, Learning Services withdrawal, peer tutor, online math tutor program and after-class teacher assistance.

Learning Services

Students with an IEP may access Learning Services throughout the school day to get assistance. Tests and exams may be written in Learning Services where support can be given as indicated on the IEP. Students who have an IEP are eligible to take a GLE course, which gives them the opportunity to receive academic assistance while earning a credit. (See course descriptions under Special Education course section.)

Course Changes: Policies and Procedures

Students wishing to change a course should consult with their Guidance counsellor. Course transfers or changes should occur within the first three weeks of the semester. Students in difficulty should change course pathways as soon as possible in the year. Students are expected to catch up on the work and all previous assignments to ensure an accurate evaluation. Parental approval is required when students add/drop or change courses.

Resource Centre

Come to the Resource Centre to find what you need for your research or for your reading pleasure. There are novels to interest every type of reader. Keep up to date about local and global events by reading daily newspapers, exploring the library's wide variety of magazines and doing online research using the online databases. If you are unsure of where to begin with a project, ask one of the library staff for help. If you have suggestions for new library resources, make sure you speak with a librarian.

Here you will also connect with our Technical Resource Assistant who helps students with technical issues such as iPad troubleshooting and repair, as well as, connecting with the school's vast computer network.

Student Responsibilities

A Note to Parents

How can parents help when their student is in secondary school? Often, the courses are unfamiliar to parents and help with homework is much more difficult for parents. The following suggestions will assist the student and build the essential partnership between home and school. Insist that the student attends school regularly and punctually. Valid absences include illness, medical, dental and legal appointments or family emergencies.

Encourage Good Study Habits

Insist that homework is done regularly and on schedule. Students should read, review notes or work on projects. This discipline is the key to scholastic success, according to many educational researchers. Limit employment hours (15 hours per week is considered the upper limit for most students), as well as evening out-of-school activities. Keep in touch! If you have concerns about your son's or daughter's progress, do not hesitate to call the school at 519-271-4500. We will gladly arrange interviews with Administration, Guidance or individual teachers.

Attendance

Parents can help by ensuring that any absences are necessary and valid. If the learning process is disrupted by irregular attendance, learning experiences are lost and cannot be made up completely. Students who habitually miss class will be disadvantaged in the evaluation processes because assessment opportunities of their work will be minimized. Our school's specific attendance procedures are outlined by the Principal and Vice-Principal during the first week of school. A Code of Conduct and Behaviour for Members of the Stratford Central SS Community Schools are established to help young people learn the skills, knowledge and values, which help them to live full and worthwhile lives. Schooling is a RIGHT, which imposes certain RESPONSIBILITIES on students. Students are expected to strive for personal excellence by arriving at class on time, with the appropriate materials, and participating actively and positively in all school activities.

Students have the right to:

- Learn in this school. It is the student's responsibility to listen to instructions and work quietly and respectfully.
- Hear and Be Heard. It is the student's responsibility to listen when someone else is speaking.
- Be Respected in this school. It is the student's responsibility to respect the opinions and feelings of others.
- Be Safe in this school. It is the student's responsibility not to threaten or physically harm anyone else.
- Privacy and Personal Space. It is the student's responsibility to respect the personal property of others and to respect the right to privacy.

Central has rules or guidelines for appropriate behaviour. These guidelines, which are established by students, parents, community representatives, staff and administrators, reflect the school's philosophy of consultation and mutual respect. They are intended to ensure the well being and security of everyone at Central. Each September, a Student Handbook and Code of Conduct Booklet is distributed and reviewed with all students.

Special Programs

Advanced Placement Program

Advanced Placement offers enrichment to senior high school students as a way of connecting them to greater success and wider opportunities when they enter university. At certain universities a student who has successfully completed AP in a subject area may be permitted to bypass the first year university course in that subject and directly enter a second year course. At many universities they may actually be granted a first year credit in the subject. Research has demonstrated that AP students are more likely to succeed in their first year of university and beyond because AP encourages students to be more independent and self-motivated. There are currently four AP courses offered at Central; Visual Arts, World History, English and Biology.

COPE (Cooperative Opportunities Providing Education)

COPE is an alternative education program. Students must be at least 16 years of age. The program offers an off-campus education opportunity to obtain an Ontario Secondary School Diploma for students who are currently out of school or who may not have met success in a traditional classroom setting. It is a continuous entry program which includes a cooperative education experience with the delivery of credit courses through correspondence.

French Immersion at Stratford Central Secondary School

The aim of the French Immersion program at Stratford Central Secondary School is to continue to develop and refine students' ability to communicate in French as well as to expand their knowledge of the language through the study of francophone literature. By the end of the four-year program, students will participate easily in conversations and discussions; will be able to take courses at the college or university level in which French is the language of instruction; and will be able to accept employment in which French is the working language.

The study of French is an important part of the secondary school curriculum. French is not only one of Canada's two official languages, but is also widely used around the world. Through learning a second language, students can strengthen their first-language skills and enhance their critical and creative thinking abilities; they also tend to become more accepting and respectful of other cultures. In addition, the ability to communicate in another language provides students with a distinct advantage in a number of careers, both in Canada and internationally.

Students may work toward a certificate in French Immersion. Students working toward this goal would be required to complete the sequence of four courses in French Immersion Language (FIF) and six courses in other subjects taught in French Immersion. Alternately, students may earn a certificate in Extended French if the student successfully completes the sequence of four courses in French Immersion Language (FIF) and a minimum of three courses in other subjects taught in French Immersion. During the four year program, students are encouraged to seek opportunities to broaden their confidence in the second language through partnerships with our feeder schools, through student exchanges and travel, and through work experiences in French.

Gifted Programs

Identified gifted students may participate in modules in Grades 9 and 10. Modules are offered on a range of topics. Students should check course listings for enriched classes in core subjects. Other opportunities for enrichment include university liaison programs designed to introduce students to post-secondary opportunities. These programs all require registration and, in some cases, competition for acceptance. To find out about these programs, students should contact the Learning Services Teacher.

Specialist High Skills Major (SHSM)

Arts & Culture and Information & Communication Technology

The Specialists High Skills Major (SHSM) enables students at Stratford Central to customize their high school experience to suit their interests and talents and prepare for a successful post-secondary transition to apprenticeship training, college, university, or employment; while meeting the requirements of the Ontario Secondary School Diploma. Students will earn recognized certifications and training, engage in experiential learning through reach-ahead activities to apprenticeship, college, or university experiences; and engage in cooperative education, job shadowing and work experience while meeting their diploma requirements.

Concurrent Education

(Stratford Central S.S. and Stratford Northwestern S.S.)

Students who attend Stratford Central SS and Stratford Northwestern SS are reminded of the vast program and course opportunities that are available to them in the two schools. In order to broaden your educational experience, a Northwestern student may desire to take a course(s) at Central or a Central student may desire to take a course(s) at Northwestern while remaining a student and receiving their diploma at their home school. If a student at either school is unable to schedule a desired class in his or her home school we encourage you to speak with your Guidance Department who will work to see if your request can be accommodated between the two schools. Stratford Northwestern, for example, offers a broader selection of courses in Technological Education at the senior level and offers a Specialist High Skills Major in Energy, Health & Wellness, Hospitality & Tourism, Manufacturing & Transportation. Stratford Central offers a broader selection of courses in The Arts and offers a Specialist High Skills Major in Arts & Culture (which includes

Theatre Production) and a Specialist High Skills Major in Information & Communication Technology. Stratford Central also offers Advanced Placement courses at the senior level. Both schools have many diversified courses our students may wish to consider to get the best educational opportunities available to pursue their many pathways to work, apprenticeship, college or university. We encourage you to consider concurrent education when you are making your course selections in February at both Stratford Northwestern and Stratford Central. For further information about concurrent education please contact Chris Cassone (chris.cassone@ed.amdsb.ca).

Experiential Learning

Schools are offering more opportunities to customize your high school experience and build on your strengths and interests through a variety of new and enhanced learning options including Experiential Learning. Experiential Learning programs such as Co-op, Dual Credits, Ontario Youth Apprenticeship Program (OYAP) and Specialist High Skills Major (SHSM) enhance your academic background and provide you with opportunities to gain valuable experiences in our community.

No matter what your post-secondary pathway may be, experiential learning can assist you in making career decisions and help you develop the knowledge, skills and habits required in the workplace. All forms of experiential learning are a valuable complement to your post-secondary preparation and future employment.

Dual Credit Offerings at Conestoga, Fanshawe and Lambton Colleges

What is a Dual Credit Program

Dual credit programs allow senior high school students the opportunity to earn high school and college credits at the same time. Students typically attend Conestoga, Fanshawe or Lambton College's campuses once a week for a fifteen week period. This unique arrangement allows you, the student, the chance to experience life and learning in a college environment and allows you to fast track towards your post-secondary goals.

Examples of dual credit offerings include:

- Digital Photography
- Basic Plumbing
- Basic Electrical
- Intro to Early Childhood Education
- Baking & Pastry Arts
- Basic Welding Process and Fabricating
- Health and Wellness Fundamentals
- Recreation and Leisure

Program availability is subject to change. A maximum of 4 college-delivered dual credits can be counted as optional credits towards the Ontario Secondary School Diploma (OSSD). Dual Credits cannot be used as substitutions for compulsory credit requirements.

What does it cost?

You pay nothing. All books, transportation and tuition are paid for through grants from the School College Work Initiative (SCWI). SCWI is a collaborative partnership between the Ministry of Education and the Ministry of Advanced Education and Skills Development.

What makes a student eligible?

Dual credit programs are intended to assist secondary school students in the completion of their OSSD and provide a successful transition to college and apprenticeship programs. As well, students in Specialist High Skills Major (SHSM) programs and the Ontario Youth Apprenticeship Programs (OYAP) are eligible to enroll. Enrolment in half or full day Co-op allows greater flexibility to participate.

How do I apply?

You **MUST** be referred to the program through your School Student Success Team. Avon Maitland College partners will not accept applications directly.

To find out what dual credit offerings are available and to take advantage of this great opportunity, contact your Guidance Counselor, Student Success teacher or Co-op teacher for an up-to-date listing of course offerings and to obtain an application form. More information can be found at successforlife.ca.

Ontario Youth Apprenticeship Program

- Are you a hands on learner?
- Do you like to solve problems?
- Are you good at fixing things?
- Do you find it difficult to sit in a classroom all day?

If you answered yes to any of the above, the apprenticeship pathway may be for you!

Get started on your apprenticeship while in high school. The Ontario Youth Apprenticeship Program (OYAP) allows you to be considered an OYAP Participant and earn cooperative education credits for work experience in an apprenticeable trade. You may or may not be formally registered as an apprentice while attending secondary school. To participate in OYAP you must: be at least 16 years of age, have completed a minimum of 16 credits, be a full-time student working towards completion of your diploma and complete the OYAP participant form.

A student who participates in OYAP must have a Personalized Placement Learning Plan (PPLP) that is based on the on-the-job training requirements outlined in the government approved training standard for that trade. Training Standard competency booklets can be found at the Ontario College of Trades website. The OYAP program is funded by the

Government of Ontario, Ministry of Advanced Education and Skills Development.

Fast track through an apprenticeship now and take advantage of Dual Credit and Specialist High Skills Major opportunities. See your Guidance Counsellor or Co-op teacher to apply. For more information, visit successforlife.ca and oyap.com.

Specialist High Skills Majors

The SHSM is a specialized program that allows students to focus their learning on a specific economic sector while meeting the requirements for the Ontario Secondary School Diploma (OSSD) and assist in their transition from secondary school to apprenticeship training, college, university, or the workplace. SHSM allow students to focus on a career path that matches their skills and interests. Visit www.successforlife.ca to view the SHSM sectors available at this school.

Every SHSM must include the following five components:

- A bundle of 8-10 Grade 11 and 12 courses in the selected field that includes 2 cooperative education credits.
- Sector-recognized certifications and/or training courses.
- Experiential learning activities within the sector.
- Reach Ahead experiences connected with the student's chosen post-secondary pathway.
- Development of key Essential Skills and Work Habits required for the sector; and the use of the Ontario Skills Passport (OSP) for purposes of documentation.

Benefits to students enrolled in a SHSM program:

- Customize their secondary school education to suit their interests and talents.
- Develop specialized knowledge and skills.
- Earn credits that post-secondary educational institutions and the sector recognize.
- Gain sector-recognized certification and career-relevant training.
- Develop essential skills and work habits documented through the Ontario Skills Passport.
- Identify, explore and refine career goals and make informed decisions about their future.
- Remain flexible, with the option to shift between pathways, should their goals and plans change.

For more information, visit www.successforlife.ca

Avon Maitland District E-Learning Centre (AMDEC)

AMDEC is a fully online secondary school within the Avon Maitland DSB, which offers courses from grade 9 to grade 12 in most subject areas. Our courses are taught by experienced AMDSB teachers who are committed to student success through a quality eLearning experience. Your success as a student is also supported by our principal, vice principal, program coordinator, guidance counsellor, technical help department, office staff and the home school. Our goal at AMDEC is to provide you with the best possible eLearning experience. We believe that our

program provides an excellent educational opportunity for all of our students.

AMDEC delivers a non-semestered, modified continuous intake program. With the permission of your home school, you may start AMDEC courses any time between September and mid-February, but all students must finish their courses by early June. You have flexible deadlines for your assignments; however, you are responsible for establishing an assignment completion schedule that meets both AMDEC's due dates and your own needs (for example, completing the course by the end of first semester or meeting post-secondary mark submission deadlines). You are encouraged to complete courses prior to the final due date. Module completion requirements and a list of important due dates are posted in the Student Handbook and are also available on our website: www.amdec.ca.

Students wishing to take an AMDEC course must register through the guidance department of their home school. You may consider eLearning courses for a number of reasons: to take a course that is not offered at your home school; to solve a timetable conflict; and to experience eLearning before starting post-secondary education. To succeed in eLearning, you need to have: self-motivation, organization, self-direction, time management, computer proficiency, and honesty.

AMDEC's course offerings are determined in the spring of each school year. A list of courses that are currently offered can be found under the Courses tab on our website: www.amdec.ca.

What You Need to Graduate

18 Compulsory Credits

Students must earn the following compulsory credits to obtain the Ontario Secondary School Diploma:

4 English Credits (1 credit per grade)

- Grade 9
- Grade 10
- Grade 11
- Grade 12

3 Mathematics Credits (1 credit in grade 11 or 12)

- Grade 9
- Grade 10
- Grade 11 or 12

2 Science Credits

- Grade 9
- Grade 10
- **1 Canadian History Credit**
- **1 Canadian Geography Credit**
- **1 Arts Credit**
- **1 Health & Physical Education Credit**
- **1 French as a Second Language Credit**

- **0.5 Career Studies Credit**
- **0.5 Civics Credit**

Plus one credit from each of the following groups

- **1 Additional Credit** in English, or French as second language, or a native language, or a classical or an international language, or social sciences and the humanities, or Canadian and world studies, or guidance and career education, or cooperative education
- **1 Additional Credit** in health & physical education, or the arts, or business studies, or French as a second language, or cooperative education
- **1 Additional Credit** in science (grade 11 or 12), or technological education, or French as a second language, or computer studies, or cooperative education.

In Addition, Students Must Complete:

- 12 Optional Credits
- 40 Hours of Community Services Activities
- The Provincial Literacy Requirement

The Arts

Dance

ATC10, Dance, Grade 9, Open

This course gives students the opportunity to explore their technical and compositional skills by applying the elements of dance and the tools of composition in a variety of performance situations. Students will generate movement through structured and unstructured improvisation, demonstrate an understanding of safe practices with regard to themselves and others in the dance environment, and identify the function and significance of dance within the global community.

ATC20, Dance, Grade 10, Open

This course emphasizes the development of students' technique and creative skills relating to the elements of dance and the tools of composition in a variety of performance situations. Students will identify responsible personal and interpersonal practices related to dance processes and production, and will apply technologies and techniques throughout the process of creation to develop artistic scope in the dance arts.

ATC3M, Dance, Grade 11, University/College Preparation

This course emphasizes the development of students' artistry, improvisational and compositional skills, and technical proficiency in global dance genres from around the world. Students will apply dance elements, techniques, and tools in a variety of ways, including performance situations; describe and model responsible practices related to the dance environment; and reflect on how the study of dance affects personal and artistic development. **Prerequisite: ATC10 or ATC20**

ATC4M, Dance, Grade 12, University/College Preparation

This course emphasizes the development of students' technical proficiency, fluency in the language of movement in dance genres from around the world, and understanding of dance science. Students will explain the social, cultural, and historical contexts of dance; apply the creative process through the art of dance in a variety of ways; and exhibit an understanding of the purpose and possibilities of continuing engagement in the arts as a lifelong learner.

Prerequisite: ATC3M

Dramatic Arts

ADA10, Dramatic Arts, Grade 9, Open

This course provides opportunities for students to explore dramatic forms and techniques, using material from a wide range of sources and cultures. Students will use the elements of drama to examine situations and issues that are relevant to their lives. Students will create, perform, discuss, and analyze drama and then reflect on the experiences to develop an understanding of themselves, the art form, and the world around them.

ADA20, Dramatic Arts, Grade 10, Open

This course provides opportunities for students to explore dramatic forms, conventions, and techniques. Students will explore a variety of dramatic sources from various cultures and representing a range of genres. Students will use the elements of drama in creating and communicating through dramatic works. Students will assume responsibility for decisions made in the creative and collaborative processes and will reflect on their experiences.

**ADA3M,
Dramatic Arts,
Grade 11, University/College Preparation**

This course requires students to create and to perform in dramatic presentations. Students will analyze, interpret, and perform dramatic works from various cultures and time periods. Students will research various acting styles and conventions that could be used in their presentations, and analyze the functions of playwrights, directors, actors, designers, technicians, and audiences. **Prerequisite: ADA10 or ADA20**

**ADA4M,
Dramatic Arts,
Grade 12, University/College Preparation**

This course requires students to experiment individually and collaboratively with forms and conventions of both drama and theatre from various cultures and time periods. Students will interpret dramatic literature and other texts and media sources while learning about various theories of directing and acting. Students will examine the significance of dramatic arts in various cultures, and will analyze how the knowledge and skills developed in drama are related to their personal skills, social awareness, and goals beyond secondary school. **Prerequisite: ADA3M**

Instrumental Music

**AMI10,
Instrumental Music,
Grade 9, Open**

This course emphasizes the creation and performance of music at a level consistent with previous experience and is aimed at developing technique, sensitivity, and imagination. Students will develop musical literacy skills by using the creative and critical analysis processes in composition, performance, and a range of reflective and analytical activities. Students will develop an understanding of the conventions and elements of music and of safe practices related to music, and will develop a variety of skills transferable to other areas of their life.

Students will learn to play a woodwind or brass instrument and the course is open to all Grade 9 students regardless of musical background.

**AMI20,
Instrumental Music,
Grade 10, Open**

This course emphasizes the creation and performance of music at a level consistent with previous experience. Students will develop musical literacy skills by using the creative and critical analysis processes in composition, performance, and a range of reflective and analytical activities. Students will develop their understanding of musical conventions, practices, and terminology and apply the elements of music in a range of activities. They will also explore the function of music in society with reference to the self, communities, and cultures. This course emphasizes music performance on a band instrument. **Recommended preparation: AMI10**

**AMI3M,
Instrumental Music,
Grade 11, University/College Preparation**

This course provides students with opportunities to develop their musical literacy through the creation, appreciation, analysis, and performance of music, including traditional, commercial, and art music. Students will apply the creative process when performing appropriate technical exercises and repertoire and will employ the critical analysis processes when reflecting on, responding to, and analysing live and recorded performances. Students will consider the function of music in society and the impact of music on individuals and communities. They will explore how to apply skills developed in music to their life and careers. They will continue to increase their understanding of the elements of music while developing their technical and imaginative abilities. **Prerequisite: AMI10 or AMI20 (both strongly recommended)**

**AMI4M,
Instrumental Music,
Grade 12, University/College Preparation**

This course enables students to enhance their musical literacy through the creation,

appreciation, analysis, and performance of music. Students will perform traditional, commercial, and art music, and will respond with insight to live and recorded performances. Students will enhance their understanding of the function of music in society and the impact of music on themselves and various communities and cultures. Students will analyse how to apply skills developed in music to their life and careers. They will also complete complex creative projects. **Prerequisite: AMI3M**

**AMS10,
Instrumental Music - Strings,
Grade 9, Open**

This course emphasizes the creation and performance of music at a level consistent with previous experience and is aimed at developing technique, sensitivity, and imagination. Students will develop musical literacy skills by using the creative and critical analysis processes in composition, performance, and a range of reflective and analytical activities. Students will develop an understanding of the conventions and elements of music and of safe practices related to music, and will develop a variety of skills transferable to other areas of their life. This is an introductory course in strings (violin, viola, cello and bass), geared to senior students who have experience reading music. **Recommended preparation: AMI10 or AMI20**

**AMS20,
Instrumental Music - Strings,
Grade 10, Open**

This course emphasizes the creation and performance of music at a level consistent with previous experience. Students will develop musical literacy skills by using the creative and critical analysis processes in composition, performance, and a range of reflective and analytical activities. Students will develop their understanding of musical conventions, practices, and terminology and apply the elements of music in a range of activities. They will also explore the function of music in society with reference to the self, communities, and cultures. Students will also be

required to develop a thorough understanding of the language of music, including the elements, terminology and history with specific application to string instruments. This course is a continuation of the material learned in AMS10. **Recommended preparation: AMS10 or AMI20**

Symphonic Band

**AMR20, (0.5 Credit)
Repertoire,
Grade 10, Open**

This half-credit course focuses on the performance of Symphonic Band repertoire. This course emphasizes the creation and performance of music at a level consistent with previous experience. Students will develop musical literacy skills by using the creative and critical analysis processes in composition, performance, and a range of reflective and analytical activities. Students will develop their understanding of musical conventions, practices, and terminology and apply the elements of music in a range of activities. They will also explore the function of music in society with reference to the self, communities, and cultures. **Co-requisite: AMI20**

**AMR3M, (0.5 Credit)
Repertoire,
Grade 11, University/College Preparation Part 1**

This half-credit course focuses on the performance of Symphonic Band repertoire. This course provides students with opportunities to develop their musical literacy through the creation, appreciation, analysis, and performance of music, including traditional, commercial, and art music. Students will apply the creative process when performing appropriate technical exercises and repertoire and will employ the critical analysis processes when reflecting on, responding to, and analyzing live and recorded performances. Students will consider the function of music in society and the impact of music on individuals and communities. They will explore how to apply skills developed in music to their life and careers. **Prerequisite: AMI10 or AMI20 (both recommended); Co-requisite: AMI3M**

AMR4M, (0.5 Credit)

Repertoire,

Grade 12, University/College Preparation Part 2

This half-credit course focuses on the performance of Symphonic Band repertoire. This course enables students to enhance their musical literacy through the creation, appreciation, analysis, and performance of music. Students will perform traditional, commercial, and art music, and will respond with insight to live and recorded performances. Students will enhance their understanding of the function of music in society and the impact of music on themselves and various communities and cultures. Students will analyse how to apply skills developed in music to their life and careers. **Prerequisite: AMI3M; Co-requisite: AMI4M**

Jazz Band

AMH3M, (0.5 Credit)

Stage-Band Music,

Grade 11, University/College Preparation Part 1

This half-credit course focuses on jazz technique and the performance of jazz music. This course provides students with opportunities to develop their musical literacy through the creation, appreciation, analysis, and performance of music, including traditional, commercial, and art music. Students will apply the creative process when performing appropriate technical exercises and repertoire and will employ the critical analysis processes when reflecting on, responding to, and analysing live and recorded performances. Students will consider the function of music in society and the impact of music on individuals and communities. They will explore how to apply skills developed in music to their life and careers. **Prerequisite: AMI10 or AMI20 (both recommended); Co-requisite: AMI3M, AMR3M**

AMH4M, (0.5 Credit)

Stage-Band Music,

Grade 12, University/College Preparation Part 2

This half-credit course focuses on jazz technique and the performance of jazz music.

This course enables students to enhance their musical literacy through the creation, appreciation, analysis, and performance of music. Students will perform traditional, commercial, and art music, and will respond with insight to live and recorded performances. Students will enhance their understanding of the function of music in society and the impact of music on themselves and various communities and cultures. Students will analyse how to apply skills developed in music to their life and careers. **Prerequisite: AMI3M, AMR3M or AMH3M; Co-requisites: AMI4M, AMR4M**

Vocal/Choral Music

AMV10,

Music - Vocal/Choral,

Grade 9, Open

This course emphasizes the creation and performance of music at a level consistent with previous experience and is aimed at developing technique, sensitivity, and imagination. Students will develop musical literacy skills by using the creative and critical analysis processes in composition, performance, and a range of reflective and analytical activities. Students will develop an understanding of the conventions and elements of music and of safe practices related to music, and will develop a variety of skills transferable to other areas of their life. Students will explore the vast repertoire of vocal and choral music ranging from the Middle Ages to the present, from Gregorian Chant to vocal jazz, with special attention given to Canadian folk music.

AMV20,

Music - Vocal/Choral,

Grade 10, Open

This course emphasizes the creation and performance of music at a level consistent with previous experience. Students will develop musical literacy skills by using the creative and critical analysis processes in composition, performance, and a range of reflective and analytical activities. Students will develop their understanding of musical conventions, practices, and terminology and apply the

elements of music in a range of activities. They will also explore the function of music in society with reference to the self, communities, and cultures. There will also be an emphasis on sight-singing, solo and choral repertoire.

Recommended preparation: AMV10

**AMV3M,
Music - Vocal/Choral,
Grade 11, University/College Preparation**

This course provides students with opportunities to develop their musical literacy through the creation, appreciation, analysis, and performance of music, including traditional, commercial, and art music. Students will apply the creative process when performing appropriate technical exercises and repertoire and will employ the critical analysis processes when reflecting on, responding to, and analysing live and recorded performances. Students will consider the function of music in society and the impact of music on individuals and communities. They will explore how to apply skills developed in music to their life and careers. Independently and in groups, they will also plan, market, and produce music productions, making use of appropriate technology, and will evaluate the results. **Prerequisite: AMV10 or AMV20**

Guitar

**AMG3O,
Music - Guitar,
Grade 11, Open**

This course develops students' musical literacy through performance and the preparation and presentation of music productions. Students will perform works at a level consistent with previous experience. Independently and collaboratively, students will use current technology and the creative and critical analysis processes to plan, produce, present, and market musical productions. Students will respond to, reflect on, and analyse music from various genres and periods, and they will develop skills transferable to other aspects of their life and their careers. This course develops students' musical literacy through performance on the guitar and the preparation of music productions on the guitar.

Visual Arts

**AVI1O,
Visual Arts,
Grade 9, Open**

This course is exploratory in nature, offering an overview of visual arts as a foundation for further study. Students will become familiar with the elements and principles of design and the expressive qualities of various materials by using a range of media, processes, techniques, and styles. Students will use the creative and critical analysis processes and will interpret art within a personal, contemporary, and historical context.

**AVI2O,
Visual Arts,
Grade 10, Open**

This course enables students to develop their skills in producing and presenting art by introducing them to new ideas, materials, and processes for artistic exploration and experimentation. Students will apply the elements and principles of design when exploring the creative process. Students will use the critical analysis process to reflect on and interpret art within a personal, contemporary, and historical context.

**AVI3M,
Visual Arts,
Grade 11, University/College Preparation**

This course enables students to further develop their knowledge and skills in visual arts. Students will use the creative process to explore a wide range of themes through studio work that may include drawing, painting, sculpting, and printmaking, as well as the creation of collage, multimedia works, and works using emerging technologies. Students will use the critical analysis process when evaluating their own work and the work of others. The course may be delivered as a comprehensive program or through a program focused on a particular art form (e.g., photography, video, computer graphics, information design). **Prerequisite: AVI1O or AVI2O**

AWE3O,

Visual Arts: Information/Consumer Design, Grade 11, Open

This course focuses on studio activities in one or more of the visual arts. Students will create art works that explore a wide range of subject matter, and will evaluate art works using specific criteria. They will also examine historical and cultural contexts of Western art (including Canadian art) and art from various world cultures to support their study of specific media. Studio activities will focus on the graphic arts of advertising, logo design, magazine layout, digital photography, symbolism and values.

Prerequisite: AVI1O or AVI2O

AWM3M,

Visual Arts: Drawing and Painting, Grade 11, University/College Preparation

This course provides students with opportunities to further develop their skills and knowledge in visual arts. Students will explore a range of subject matter through studio activities, and will consolidate their practical skills. Students will also analyse art works and study aspects of Western art history, as well as art forms from Canada and other parts of the world. Skeletal and muscular studies of human anatomy will figure prominently. Studio projects using line, value, colour, texture and composition will involve life drawing, limited portraiture, partial and full body casting while art history components will concentrate on how the depiction of the human form evolved throughout the centuries.

Prerequisite: AVI1O or AVI2O

AVI4M,

Visual Arts, Grade 12, University/College Preparation

This course focuses on enabling students to refine their use of the creative process when creating and presenting two- and three-dimensional art works using a variety of traditional and emerging media and technologies. Students will use the critical analysis process to deconstruct art works and explore connections between art and society. The studio program enables students to explore a range of materials,

processes, and techniques that can be applied in their own art production. Students will also make connections between various works of art in personal, contemporary, historical, and cultural contexts. **Prerequisite: Visual Arts, Grade 11, University/College Preparation.**

AVI4MAP,

Visual Arts, Grade 12, University/College Preparation Advanced Placement

This course focuses on enabling students to refine their use of the creative process when creating and presenting two- and three-dimensional art works using a variety of traditional and emerging media and technologies. Students will use the critical analysis process to deconstruct art works and explore connections between art and society. The studio program enables students to explore a range of materials, processes, and techniques that can be applied in their own art production. Students will also make connections between various works of art in personal, contemporary, historical, and cultural contexts. AP Studio Art is for highly motivated and organized students who produce polished artwork of excellent quality and in the required quantity to satisfy the expectations of the Advanced Placement Program. **Prerequisite: AVI3M or AWM3M**

AWK4M,

Visual Arts: Illustration, Grade 12, University/College Preparation

This course focuses on the refinement of students' skills and knowledge in visual arts. Students will analyse art forms; use theories of art in analyzing and producing art; and increase their understanding of stylistic changes in modern and contemporary Western art, Canadian (including Native Canadian) art, and art forms from various parts of the world. Students will produce a body of work demonstrating a personal approach. Studio activities include figures in motion, facial close ups, technical illustrations, conventional story-boards, caricatures, book cover illustrations, fashion designs and designing a complete, illustrated storybook. **Prerequisite: AVI3M or AWM3M**

Business Studies

BTT1O, Information and Communication Technology in Business, Grade 9, Open

This course introduces students to information and communication technology in a business environment and builds a foundation of digital literacy skills necessary for success in a technologically driven society. Students will develop word processing, spreadsheet, database, desktop publishing, presentation software, and website design skills. Throughout the course, there is an emphasis on digital literacy, effective electronic research and communication skills, and current issues related to the impact of information and communication technology.

BBI2O, Introduction to Business, Grade 10, Open

This course introduces students to information and communication technology in a business environment and builds a foundation of digital literacy skills necessary for success in a technologically driven society. Students will develop word processing, spreadsheet, database, desktop publishing, presentation software, and website design skills. Throughout the course, there is an emphasis on digital literacy, effective electronic research and communication skills, and current issues related to the impact of information and communication technology.

BAF3M, Financial Accounting Fundamentals, Grade 11, University/College Preparation

This course introduces students to the fundamental principles and procedures of accounting. Students will develop financial analysis and decision-making skills that will assist them in future studies and/or career opportunities in business. Students will acquire an understanding of accounting for a service and a merchandising business, computerized accounting, financial analysis, and ethics and current issues in accounting.

ICS3C, Introduction to Computer Programming, Grade 11, College Preparation

This course introduces students to computer programming concepts and practices. Students will write and test computer programs, using various problem-solving strategies. They will learn the fundamentals of program design and apply a software development life-cycle model to a software development project. Students will also learn about computer environments and systems, and explore environmental issues related to computers, safe computing practices, emerging technologies, and postsecondary opportunities in computer-related fields.

ICS3U, Introduction to Computer Science, Grade 11, University Preparation

This course introduces students to computer science. Students will design software independently and as part of a team, using industry standard programming tools and applying the software development life-cycle model. They will also write and use sub-programs within computer programs. Students will develop creative solutions for various types of problems as their understanding of the computing environment grows. They will also explore environmental and ergonomic issues, emerging research in computer science and global career trends in computer-related fields.

BBB4M, International Business Fundamentals, Grade 12, University/College Preparation

This course provides an overview of the importance of international business and trade in the global economy and explores the factors that influence success in international markets. Students will learn about the techniques and strategies associated with marketing, distribution, and managing international business effectively. This course prepares students for post-secondary programs in business, including international business, marketing, and management.

**ICS4C,
Computer Programming,
Grade 12, College Preparation**

This course further develops students' computer programming skills. Students will learn object-oriented programming concepts, create object-oriented software solutions and design graphical user interfaces. Student teams will plan and carry out a software development project using industry-standard programming tools and proper project management techniques. Students will also investigate ethical issues in computing and expand their understanding of environmental issues, emerging technologies and computer-related careers. **Prerequisite: ICS3C**

**ICS4U,
Computer Science,
Grade 12, University Preparation**

This course enables students to further develop knowledge and skills in computer science. Students will use modular design principles to create complex and fully documented programs, according to industry standards. Student teams will manage a large software development project, from planning through to project review. Students will also analyse algorithms for effectiveness. They will investigate ethical issues in computing and further explore environmental issues, emerging technologies, areas of research in computer science and careers in the field. **Prerequisite: ICS3U**

Canadian & World Studies

**CGC1D,
Issues in Canadian Geography,
Grade 9, Academic**

This course examines interrelationships within and between Canada's natural and human systems and how these systems interconnect with those in other parts of the world. Students will explore environmental, economic, and social geographic issues relating to topics such as transportation options, energy choices, and urban development. Students will apply the concepts of geographic thinking and the

geographic inquiry process, including spatial technologies, to investigate various geographic issues and to develop possible approaches for making Canada a more sustainable place to live.

**CGC1P,
Issues in Canadian Geography,
Grade 9, Applied**

This course focuses on current geographic issues that affect Canadians. Students will draw on their personal and everyday experiences as they explore a range of issues, including food and water supplies, competing land uses, and interactions with the natural environment, developing their awareness that issues that affect their lives are interconnected with issues in other parts of the world. Students will apply the concepts of geographic thinking and the geographic inquiry process, including spatial technologies, to investigate choices related to sustainable living in Canada.

**CGG3O,
Travel and Tourism: A Geographic Perspective,
Grade 11, Open**

This course focuses on issues related to travel and tourism within and between various regions of the world. Students will investigate unique environmental, sociocultural, economic, and political characteristics of selected world regions. They will explore travel patterns and trends as well as tensions related to tourism, and will predict future tourism destinations. Students will apply the concepts of geographic thinking and the geographic inquiry process, including spatial technologies, to investigate the impact of the travel industry on natural environments and human communities.

Prerequisite: CGC1D or CGC1P

**CGW4U,
World Issues: A Geographic Analysis,
Grade 12, University Preparation**

This course looks at the global challenge of creating a more sustainable and equitable world. Students will explore a range of issues involving environmental, economic, social, and geopolitical interrelationships, and will examine governmental policies related to these issues.

Students will apply the concepts of geographic thinking and the geographic inquiry process, including spatial technologies, to investigate these complex issues, including their impact on natural and human communities around the world. **Prerequisite: any university or university/college preparation course in Canadian and World Studies, English or Social Sciences and Humanities.**

History

CHC2D, Canadian History Since World War 1, Grade 10, Academic

This course explores social, economic, and political developments and events and their impact on the lives of different groups in Canada since 1914. Students will examine the role of conflict and cooperation in Canadian society, Canada's evolving role within the global community, and the impact of various individuals, organizations, and events on Canadian identity, citizenship, and heritage. They will develop their ability to apply the concepts of historical thinking and the historical inquiry process, including the interpretation and analysis of evidence, when investigating key issues and events in Canadian history since 1914.

CHC2DE, Canadian History Since World War 1, Grade 10, Academic, Enriched

This course explores social, economic, and political developments and events and their impact on the lives of different groups in Canada since 1914. Students will examine the role of conflict and cooperation in Canadian society, Canada's evolving role within the global community, and the impact of various individuals, organizations, and events on Canadian identity, citizenship, and heritage. They will develop their ability to apply the concepts of historical thinking and the historical inquiry process, including the interpretation and analysis of evidence, when investigating key issues and events in Canadian history since 1914. The curriculum will be enriched through

the in-depth study of selected topics in daily class work and discussion, group work and individually tailored assignments and projects.

CHC2L, Canadian History, Grade 10, Locally Developed

This course focuses on the connections between the student and key people, events, and themes in Canadian history from World War I to the present. Students prepare for the Grades 11 and 12 Workplace Preparation history courses through the development and extension of historical literacy and inquiry skills. Students explore a variety of topics highlighting individuals and events that have contributed to the story of Canada. The major themes of Canadian identity, internal and external relationships, and changes since 1914, are explored through guided investigation. Students have the opportunity to extend analytical skills with a focus on identifying and interpreting events and perspectives and making connections. Students practice reading, writing, visual, and oral literacy skills, and mathematical literacy skills to identify and communicate ideas in a variety of forms. **Note: This course is offered in alternating years: 2017-18, 2019-20**

CHC2P, Canadian History Since World War 1, Grade 10, Applied

This course focuses on the social context of historical developments and events and how they have affected the lives of people in Canada since 1914. Students will explore interactions between various communities in Canada as well as contributions of individuals and groups to Canadian heritage and identity. Students will develop their ability to apply the concepts of historical thinking and the historical inquiry process, including the interpretation and analysis of evidence, when investigating the continuing relevance of historical developments and how they have helped shape communities in present-day Canada.

CHV2O, (0.5 Credit)
Civics and Citizenship,
Grade 10, Open

This course explores rights and responsibilities associated with being an active citizen in a democratic society. Students will explore issues of civic importance such as healthy schools, community planning, environmental responsibility, and the influence of social media, while developing their understanding of the role of civic engagement and of political processes in the local, national, and/or global community. Students will apply the concepts of political thinking and the political inquiry process to investigate, and express informed opinions about, a range of political issues and developments that are both of significance in today's world and of personal interest to them.

CHA3U,
American History,
Grade 11, University Preparation

This course traces the social, economic, and political development of the United States from colonial times to the present. Students will examine issues of diversity, identity and culture that have influenced the country's social and political formation and will consider the implications of its expansion into a global superpower. Students will use critical-thinking and communication skills to determine causal relationships, evaluate multiple perspectives, and present their own points of view.

Prerequisite: CHC2D or CHC2P

CHT3O,
World History Since 1900:
Global and Regional Perspective,
Grade 11, Open

This course focuses on major developments in world history from 1900 to the present. Students will explore the causes and consequences of global and regional conflicts as well as responses to social, economic, and political developments in various countries and regions. Students will extend their ability to apply the concepts of historical thinking and the historical inquiry process, including

the interpretation and analysis of evidence, when investigating historical developments and events, including those that continue to affect people in various parts of the world.

Prerequisite: CHC2D or CHC2P or a locally developed compulsory course (LDCC)

CHW3M,
World History to the Fifteenth Century,
Grade 11, University/College Preparation

This course explores the history of various societies around the world, from earliest times to around 1500 CE. Students will examine life in and the legacy of various ancient and pre-modern societies throughout the world, including those in, Africa, Asia, Europe, and the Americas. Students will extend their ability to apply the concepts of historical thinking and the historical inquiry process, including the interpretation and analysis of evidence, when investigating social, political, and economic structures and historical forces at work in various societies and in different historical eras.

Prerequisite: CHC2D or CHC2P

NDA3M,
Current Aboriginal Issues In Canada,
Grade 11, University/College Preparation

This course focuses on existing and emerging issues of national and regional importance of concern to Aboriginal peoples in Canada. Students will analyze diverse perspectives from a variety of sources such as media, academic works and public opinion polls on events and developments related to land, community, governance, identity and culture. Using political thinking concepts and the political inquiry process students will explore their own and others' ideas, investigate an issue to determine what needs to change, why and appropriate problem-solving strategies. **Prerequisite:**

CHC2D or CHC2P

CHY4U,
World History Since the Fifteenth Century,
Grade 12, University Preparation

This course traces major developments and events in world history since approximately 1450. Students will explore social, economic,

and political changes, the historical roots of contemporary issues, and the role of conflict and cooperation in global interrelationships. They will extend their ability to apply the concepts of historical thinking and the historical inquiry process, including the interpretation and analysis of evidence, as they investigate key issues and assess societal progress or decline in world history. **Prerequisite: Any university or university/college preparation course in Canadian and world studies, English, or social sciences and humanities.**

CHY4UAP,
World History Since the Fifteenth Century,
Grade 12, University Preparation Advanced Placement

This course traces major developments and events in world history since approximately 1450. Students will explore social, economic, and political changes, the historical roots of contemporary issues, and the role of conflict and cooperation in global interrelationships. They will extend their ability to apply the concepts of historical thinking and the historical inquiry process, including the interpretation and analysis of evidence, as they investigate key issues and assess societal progress or decline in world history. This course also investigates the major trends in European History from 1450 to the present. **Prerequisite: any university or university/ college preparation course in Canadian and World Studies, English or Social Sciences and Humanities. Recommended: CHA3UE, ENG4U**

NDW4M,
Issues of Indigenous Peoples in a Global Context,
Grade 12, University/College Preparation

This course examines historical and contemporary issues of concern to Indigenous peoples from a global perspective. Students will explore the richness, depth, and diversity of Indigenous cultures, traditions and knowledge. They will consider how diverse Indigenous communities persevere despite recent global environmental and economic trends. Topics such as identity, social justice, human rights and abuses,

spirituality, resistance and protest for change will be investigated. **Prerequisite: any university, university/college or college preparation course in Canadian and World Studies or Social Sciences and Humanities or NDA3M**

Law & Politics

CLU3M,
Understanding Canadian Law,
Grade 11, University/College Preparation

This course explores Canadian law, with a focus on legal issues that are relevant to the lives of people in Canada. Students will gain an understanding of rights and freedoms in Canada, our legal system, and family, contract, employment, tort, and criminal law. Students will use case studies and apply the concepts of legal thinking and the legal inquiry process to develop legal reasoning skills and to formulate and communicate informed interpretations of legal issues, and they will develop the ability to advocate for new laws. **Prerequisite: CHC2D or CHC2P**

CLN4U,
Canadian and International Law,
Grade 12, University/College Preparation

This course explores a range of contemporary legal issues and how they are addressed in both Canadian and international law. Students will develop an understanding of the principles of Canadian and international law and of issues related to human rights and freedoms, conflict resolution, and criminal, environmental, and workplace law, both in Canada and internationally. Students will apply the concepts of legal thinking and the legal studies inquiry process, and will develop legal reasoning skills, when investigating these and other issues in both Canadian and international contexts. **Prerequisite: any university or university/ college preparation course in Canadian and World Studies, English or Social Sciences and Humanities**

CPW4U,
Canadian and World Politics,
Grade 12, University Preparation

This course examines Canadian and world. This course explores various perspectives on issues

in Canadian and world politics. Students will explore political decision-making and ways in which individuals, stakeholder groups, and various institutions, including different levels of government, multinational corporations, and non-governmental organizations, respond to and work to influence domestic and international developments. Students will apply the concepts of political thinking and the political inquiry process to investigate current political policies, issues, and events, and to develop and communicate informed opinions about them. **Prerequisite: any university or university/ college preparation course in Canadian and World Studies, English or Social Sciences and Humanities**

Interdisciplinary Studies

IDC30,
Interdisciplinary Studies,
Grade 11, Open

This course will help students combine the skills required for and knowledge of different subjects and disciplines to solve problems, make decisions, create personal meaning, and present findings beyond the scope of a single subject or discipline. Through individual and collaborative inquiry and research, students will analyse the connections among diverse subjects and disciplines; develop information literacy skills in analysing, selecting, evaluating, and communicating information; and become aware of a variety of resources and viewpoints on contemporary issues. They will also examine their own learning styles, relate their inquiries and research to real-life situations, and investigate career opportunities in new disciplines.

IDC40,
Interdisciplinary Studies,
Grade 12, Open

This course will help students combine the skills required for and knowledge of different subjects and disciplines to solve problems, make decisions, create personal meaning, and present findings beyond the scope of a single subject or discipline. Through individual and

collaborative inquiry and research, students will analyse the connections among diverse subjects and disciplines; develop information literacy skills in analysing, selecting, evaluating, and communicating information; and become aware of a variety of resources and viewpoints on contemporary issues. They will also examine their own learning styles, relate their inquiries and research to real-life situations, and investigate career opportunities in new disciplines.

IDC4U,
Interdisciplinary Studies,
Grade 12, University Preparation

This course will help students develop and consolidate the skills required for and knowledge of different subjects and disciplines to solve problems, make decisions, create personal meaning, and present findings beyond the scope of a single subject or discipline. Students will apply the principles and processes of inquiry and research to effectively use a range of print, electronic, and mass media resources; to analyse historical innovations and exemplary research; and to investigate real-life situations and career opportunities in interdisciplinary endeavours. They will also assess their own cognitive and affective strategies, apply general skills in both familiar and new contexts, create innovative products, and communicate new knowledge.

Prerequisites: any university or university/ college preparation course

Cooperative Education

Cooperative Education is a program that offers students the opportunity to extend classroom learning into supervised learning experiences in the community. Students can earn secondary school credits, which are related to specific school subjects in school. Cooperative Education programs combine a work placement component in the community, along with a classroom component. The classroom component includes a pre-placement session prior to attending a placement in the community and integration sessions throughout the school year. Cooperative

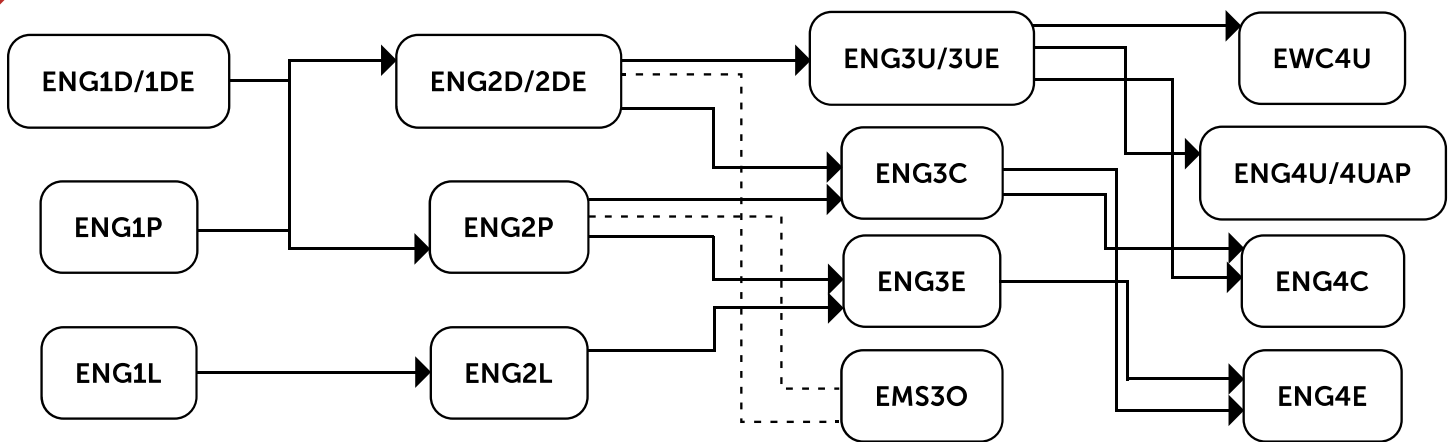

Student Success initiatives, particularly pathways programs like Specialist High Skills Majors.

Education courses can be selected in either a 2-credit or 4-credit package, depending upon the individual student's timetable and the type of placement and experience desired. Students interested in Cooperative Education must complete a cooperative education application form and interview with the cooperative education teacher prior to starting a co-op course. The student needs to demonstrate maturity, a positive attitude, an ability to be punctual and maintain regular attendance and a willingness to learn. Students must also be prepared to adhere to the policies of the workplace and school and follow health and safety regulations at the workplace. Placements are subject to availability in the community. Students are encouraged to discuss their placement choices with a co-op teacher when registering.

Ontario Youth Apprenticeship Program

Students applying for this program must register as a Cooperative Education student first. OYAP is for students who have career plans as an apprentice in the skilled trades. During secondary school, the student will begin the theory and "hands on" experience required for the apprenticeship while completing secondary school credits. Two or four Coop credits may be earned in both Grade 11 and Grade 12. An apprenticeship is a mutual agreement between a person who wants to learn the skills of a particular trade and an employer/sponsor who requires a skilled worker. If you are interested in this program, please see the Cooperative Education Department for more details. OYAP supports

English

English Compulsory

ENG1D, English, Grade 9, Academic

This course is designed to develop the oral communication, reading, writing, and media literacy skills that students need for success in their secondary school academic programs and in their daily lives. Students will analyse literary texts from contemporary and historical periods, interpret informational and graphic texts, and create oral, written, and media texts in a variety of forms. An important focus will be on the use of strategies that contribute to effective communication. The course is intended to prepare students for the Grade 10 academic English course, which leads to university or college preparation courses in Grades 11 and 12.

ENG1DE, English, Grade 9, Academic, Enriched

This course is designed to develop the oral communication, reading, writing, and media literacy skills that students need for success in their secondary school academic programs and in their daily lives. Students will analyse literary texts from contemporary and historical periods, interpret informational and graphic texts, and create oral, written, and media texts in a variety of forms. An important focus will be on the use of strategies

that contribute to effective communication. The course is intended to prepare students for the Grade 10 academic English course, which leads to university or college preparation courses in Grades 11 and 12. The modules of study in ENG1D are supplemented and enriched by a number of related activities to promote and develop critical and creative thinking in the study of language and literature, as well as to challenge students to conduct inquiry investigations arising from their own curiosity.

**ENG1L,
English,
Grade 9, Locally Developed**

This course provides foundational literacy and communication skills to prepare students for success in their daily lives, in the workplace, and in the Grade 10 LDCC course. The course is organized into strands that develop listening and talking skills, reading and viewing skills and writing skills. In all strands, the focus is on developing foundational literacy skills and in using language clearly and accurately in a variety of authentic contexts. Students develop strategies and put into practice the processes involved in talking, listening, reading, viewing, writing and thinking, and reflect regularly upon their growth in these areas.

**ENG1P,
English,
Grade 9, Applied**

This course is designed to develop the key oral communication, reading, writing, and media literacy skills students need for success in secondary school and daily life. Students will read, interpret, and create a variety of informational, literary, and graphic texts. An important focus will be on identifying and using appropriate strategies and processes to improve students' comprehension of texts and to help them communicate clearly and effectively. The course is intended to prepare students for the Grade 10 applied English course, which leads to college or workplace preparation courses in Grades 11 and 12.

**ENG2D,
English,
Grade 10, Academic**

This course is designed to extend the range of oral communication, reading, writing, and media literacy skills that students need for success in their secondary school academic programs and in their daily lives. Students will analyse literary texts from contemporary and historical periods, interpret and evaluate informational and graphic texts, and create oral, written, and media texts in a variety of forms. An important focus will be on the selective use of strategies that contribute to effective communication. This course is intended to prepare students for the compulsory Grade 11 university or college preparation course.

Prerequisite: ENG1D or ENG1P. It is strongly recommended that ENG1P students have a recommendation from their teacher

**ENG2DE,
English,
Grade 10, Academic, Enriched**

This course is designed to extend the range of oral communication, reading, writing, and media literacy skills that students need for success in their secondary school academic programs and in their daily lives. Students will analyse literary texts from contemporary and historical periods, interpret and evaluate informational and graphic texts, and create oral, written, and media texts in a variety of forms. An important focus will be on the selective use of strategies that contribute to effective communication. This course is intended to prepare students for the compulsory Grade 11 university or college preparation course. The modules of study in ENG2D are supplemented and enriched by a number of related activities to promote and develop critical and creative thinking in the study of language and literature, as well as to challenge students to conduct inquiry investigations arising from their own curiosity.

**ENG2L,
English,
Grade 10, Locally Developed**

In this course, students focus on extending

their literacy and communication skills to prepare for success in their daily lives, in the workplace, in the English Grade 11 Workplace Preparation course, or in the English: Contemporary Aboriginal Voices, Grade 11 Workplace Preparation course. The course is organized into strands that extend listening and talking skills, reading and viewing skills, and writing skills. In all strands, the focus is on refining foundational literacy skills and on using language clearly and accurately in a variety of authentic contexts. Students build on their strategies and engage in the processes involved in talking, listening, reading, viewing, writing, and thinking and reflect regularly upon their growth in these areas. **Prerequisite: ENG1D, ENG1L or ENG1P**

ENG2P,
English,
Grade 10, Applied

This course is designed to extend the range of oral communication, reading, writing, and media literacy skills that students need for success in secondary school and daily life. Students will study and create a variety of informational, literary, and graphic texts. An important focus will be on the consolidation of strategies and processes that help students interpret texts and communicate clearly and effectively. This course is intended to prepare students for the compulsory Grade 11 college or workplace preparation course. **Prerequisite: ENG1D or ENG1P**

ENG3C,
English,
Grade 11, College Preparation

This course emphasizes the development of literacy, communication, and critical and creative thinking skills necessary for success in academic and daily life. Students will study the content, form, and style of a variety of informational and graphic texts, as well as literary texts from Canada and other countries, and create oral, written, and media texts in a variety of forms for practical and academic purposes. An important focus will be on

using language with precision and clarity. The course is intended to prepare students for the compulsory Grade 12 college preparation course. **Prerequisite: ENG2P or ENG2D**

ENG3E,
English,
Grade 11, Workplace Preparation

This course emphasizes the development of literacy, communication, and critical and creative thinking skills necessary for success in the workplace and in daily life. Students will study the content, form, and style of a variety of contemporary informational, graphic, and literary texts; and create oral, written, and media texts in a variety of forms for practical purposes. An important focus will be on using language clearly and accurately in a variety of formal and informal contexts. The course is intended to prepare students for the compulsory Grade 12 workplace preparation course. **Prerequisite: ENG2P or ENG2L**

ENG3U,
English,
Grade 11, University Preparation

This course emphasizes the development of literacy, communication, and critical and creative thinking skills necessary for success in academic and daily life. Students will analyse challenging literary texts from various periods, countries, and cultures, as well as a range of informational and graphic texts, and create oral, written, and media texts in a variety of forms. An important focus will be on using language with precision and clarity and incorporating stylistic devices appropriately and effectively. The course is intended to prepare students for the compulsory Grade 12 university or college preparation course. **Prerequisite: ENG2D or ENG2DE**

ENG3UE,
English,
Grade 11, University Preparation, Enriched

This course emphasizes the development of literacy, communication, and critical and creative thinking skills necessary for success in academic and daily life. Students will analyse challenging literary texts from various periods,

countries, and cultures, as well as a range of informational and graphic texts, and create oral, written, and media texts in a variety of forms. An important focus will be on using language with precision and clarity and incorporating stylistic devices appropriately and effectively. The course is intended to prepare students for the compulsory Grade 12 university or college preparation course. The modules of study in ENG3U are supplemented and enriched by a number of related activities to promote and develop critical and creative thinking in the study of language and literature, as well as to challenge students to conduct inquiry investigations arising from their own curiosity.

Prerequisite: ENG2D or ENG2DE

**ENG4C,
English,
Grade 12, College Preparation**

This course emphasizes the consolidation of literacy, communication, and critical and creative thinking skills necessary for success in academic and daily life. Students will analyse a variety of informational and graphic texts, as well as literary texts from various countries and cultures, and create oral, written, and media texts in a variety of forms for practical and academic purposes. An important focus will be on using language with precision and clarity and developing greater control in writing. The course is intended to prepare students for college or the workplace. **Prerequisite: ENG3C**

**ENG4E,
English,
Grade 12, Workplace Preparation**

This course emphasizes the consolidation of literacy, communication, and critical and creative thinking skills necessary for success in the workplace and in daily life. Students will analyse informational, graphic, and literary texts and create oral, written, and media texts in a variety of forms for workplace-related and practical purposes. An important focus will be on using language accurately and organizing ideas and information coherently. The course is intended to prepare students for the workplace and active

citizenship. **Prerequisite: ENG3C or ENG3E**

**ENG4U,
English,
Grade 12, University Preparation**

This course emphasizes the consolidation of the literacy, communication, and critical and creative thinking skills necessary for success in academic and daily life. Students will analyse a range of challenging literary texts from various periods, countries, and cultures; interpret and evaluate informational and graphic texts; and create oral, written, and media texts in a variety of forms. An important focus will be on using academic language coherently and confidently, selecting the reading strategies best suited to particular texts and particular purposes for reading, and developing greater control in writing. The course is intended to prepare students for university, college, or the workplace. **Prerequisite: ENG3U**

**ENG4UAP,
English,
Grade 12, University Preparation,
Advanced Placement**

This course emphasizes the consolidation of the literacy, communication, and critical and creative thinking skills necessary for success in academic and daily life. Students will analyse a range of challenging literary texts from various periods, countries, and cultures; interpret and evaluate informational and graphic texts; and create oral, written, and media texts in a variety of forms. An important focus will be on using academic language coherently and confidently, selecting the reading strategies best suited to particular texts and particular purposes for reading, and developing greater control in writing. The material in this course is specifically designed to support students writing the Advanced Placement exam in May. **Prerequisite: ENG3U or ENG3UE**

English Optional

**EMS30,
Media Studies,
Grade 11, Open**

This course emphasizes knowledge and skills

that will enable students to understand media communication in the twenty-first century and to use media effectively and responsibly. Through analyzing the forms and messages of a variety of media works and audience responses to them, and through creating their own media works, students will develop critical thinking skills, aesthetic and ethical judgment, and skills in viewing, representing, listening, speaking, reading, and writing. **Prerequisite: ENG2D or ENG2P**

EWC4U,
The Writer's Craft,
Grade 12, University Preparation

This course emphasizes knowledge and skills related to the craft of writing. Students will analyse models of effective writing: use a workshop approach to produce a range of works; identify and use techniques required for specialized forms of writing: and identify effective ways to improve the quality of their writing. They will also complete a major paper as part of a creative or analytical independent study project and investigate opportunities for publication and for writing careers.

Prerequisite: ENG3U

OLC4O,
Ontario Secondary School Literacy Course,
Grade 12, Open

This course is designed to help students acquire and demonstrate the cross-curricular literacy skills that are evaluated on the Ontario Secondary School Literacy Test. Students who complete the course successfully will meet the provincial literacy requirement for graduation. Students will read a variety of informational, narrative and graphic texts and will produce a variety of forms of writing including summaries, information paragraphs, opinion pieces and news reports. Students will maintain and manage a portfolio containing a record of their reading experiences and samples of their writing. Eligibility: Students who have been eligible to write the OSSLT at least once and who have been unsuccessful. The decision to run this course will be dependent upon the number of students registered in it.

French Immersion

CGC1DF,
Enjeux géographiques du Canada,
9e, Théorique

This course examines interrelationships within and between Canada's natural and human systems and how these systems interconnect with those in other parts of the world. Students will explore environmental, economic, and social geographic issues relating to topics such as transportation options, energy choices, and urban development. Students will apply the concepts of geographic thinking and the geographic inquiry process, including spatial technologies, to investigate various geographic issues and to develop possible approaches for making Canada a more sustainable place to live. **Note: There is a possibility that all French Immersion students in grades 9 and 10 may be requested to take CHC2DF in 2017-2018 and CGC1DF in 2018-2019.**

FIF1D,
French Immersion,
9e, Théorique

This course provides opportunities for students to speak and interact in French independently in a variety of real-life and personally relevant contexts. Students will develop their ability to communicate in French with confidence by using language-learning strategies introduced in the elementary French Immersion program. Students will enhance their knowledge of the language through the study of French-Canadian literature. They will also continue to increase their understanding and appreciation of diverse French-speaking communities and to develop the skills necessary to become life-long language learners. **Prerequisite: Minimum of 3800 hours of instruction in elementary French Immersion or equivalent.**

FIF1P,
French Immersion,
9e, Appliqué

This course provides opportunities for students to communicate and exchange information in

French in a variety of real-life situations, with support as appropriate. Students will develop the key listening, speaking, reading, and writing skills introduced in the elementary French Immersion program. They will also increase their understanding and appreciation of diverse French-speaking communities, and will develop skills necessary for lifelong language learning.

Prerequisite: Minimum of 3800 hours of French instruction, or equivalent.

PPL1OF,

Vie active et santé,

9e, Ouvert

This course emphasizes regular participation in a variety of enjoyable physical activities that promote lifelong healthy active living. Students will learn movement skills and principles, ways to improve personal fitness and physical competence, and safety and injury prevention. They will investigate issues related to healthy sexuality and the use and abuse of alcohol, tobacco, and other drugs, and will participate in activities designed to develop goal setting, communication, and social skills.

CHC2DF,

Histoire du Canada depuis la Première Guerre mondiale,

10e, Théorique

This course explores social, economic, and political developments and events and their impact on the lives of different groups in Canada since 1914. Students will examine the role of conflict and cooperation in Canadian society, Canada's evolving role within the global community, and the impact of various individuals, organizations, and events on Canadian identity, citizenship, and heritage. They will develop their ability to apply the concepts of historical thinking and the historical inquiry process, including the interpretation and analysis of evidence, when investigating key issues and events in Canadian history since 1914. **Note: There is a possibility that all French Immersion students in grades 9 and 10 may be requested to take CHC2DF in 2017-2018 and CGC1DF in 2018-2019.**

CHV2OF, (0.5 Crédit)

Civisme et citoyenneté,

10e, Ouvert

This course explores rights and responsibilities associated with being an active citizen in a democratic society. Students will explore issues of civic importance such as healthy schools, community planning, environmental responsibility, and the influence of social media, while developing their understanding of the role of civic engagement and of political processes in the local, national, and/or global community. Students will apply the concepts of political thinking and the political inquiry process to investigate, and express informed opinions about, a range of political issues and developments that are both of significance in today's world and of personal interest to them.

FIF2D,

French Immersion,

10e, Théorique

This course provides students with extensive opportunities to communicate, interact, and think critically and creatively in French. Students will use a variety of language-learning strategies in listening, speaking, reading, and writing, and will respond to and interact with print, oral, visual, and electronic texts. Students will develop their knowledge of the French language through the study of contemporary and historically well-known French European literature. They will also continue to increase their understanding and appreciation of diverse French-speaking communities and to develop the skills necessary to become life-long language learners. **Prerequisite: FIF1D**

FIF2P,

French Immersion,

10e, Appliqué

This course emphasizes the development and use of skills and strategies in communication and interaction in French. Students will acquire literacy skills by using creative and critical analysis processes in listening, speaking, reading, and writing in real-life contexts. They will also increase their understanding

and appreciation of diverse French-speaking communities, and will develop skills necessary for lifelong language learning. **Prerequisite: FIF1D or FIF1P**

GLC2OF, (0.5 Cr dit)
Exploration de carri re,
10e, Ouvert

This course teaches students how to develop and achieve personal goals for future learning, work, and community involvement. Students will assess their interests, skills, and characteristics and investigate current economic and workplace trends, work opportunities, and ways to search for work. The course explores postsecondary learning and career options, prepares students for managing work and life transitions, and helps students focus on their goals through the development of a career plan.

FIF3U,
French Immersion,
11e, Th orique

This course provides opportunities for students to consolidate the communication skills required to speak and interact with increasing confidence and accuracy in French in a variety of academic and social contexts. Students will apply language-learning strategies while exploring a variety of concrete and abstract topics, and will increase their knowledge of the language through the study of French literature from around the world. They will also continue to deepen their understanding and appreciation of diverse French-speaking communities and to develop the skills necessary to become life-long language learners. **Prerequisite: FIF2D**

TGJ3MF,
Technologie des communications,
11e, Pr universitaire/Pr coll gial

This course examines communications technology from a media perspective. Students will develop knowledge and skills as they design and produce media projects in the areas of live, recorded, and graphic communications. These areas may include TV, video, and movie production; radio and audio production; print

and graphic communications; photography; digital imaging; broadcast journalism; and interactive new media. Students will also develop an awareness of related environmental and societal issues and explore college and university programs and career opportunities in the various communications technology fields. **Recommended preparation: TGJ2O**

FIF4U,
French Immersion,
12e, Pr universitaire

This course provides students with extensive opportunities to communicate, interact, and think critically and creatively in French. Students will consolidate language-learning strategies and apply them while communicating about concrete and abstract topics, and will independently respond to and interact with a variety of oral and written texts. Students will study a selection of French literature from the Middle Ages to the present. They will also continue to enrich their understanding and appreciation of diverse French-speaking communities and to develop the skills necessary to become life-long language learners.

Prerequisite: FIF3U

HSB4UF,
Changements et d fis sociaux,
12e, Pr universitaire/Pr coll gial

This course focuses on the use of social science theories, perspectives, and methodologies to investigate and explain shifts in knowledge, attitudes, beliefs, and behaviour and their impact on society. Students will critically analyse how and why cultural, social, and behavioural patterns change over time. They will explore the ideas of social theorists and use those ideas to analyse causes of and responses to challenges such as technological change, deviance, and global inequalities. Students will explore ways in which social science research methods can be used to study social change.

Note: This course will not be running in 2017-2018 but will be running in 2018-2019.

**IDC4OF/IDC4UF,
Études interdisciplinaires,
12e, Préuniversitaire/Précollégial**

This course will help students develop and consolidate the skills required for and knowledge of different subjects and disciplines to solve problems, make decisions, create personal meaning, and present findings beyond the scope of a single subject or discipline. Students will apply the principles and processes of inquiry and research to effectively use a range of print, electronic, and mass media resources; to analyse historical innovations and exemplary research; and to investigate real-life situations and career opportunities in interdisciplinary endeavours. They will also assess their own cognitive and affective strategies, apply general skills in both familiar and new contexts, create innovative products, and communicate new knowledge.

Prerequisites: Any university or university/college preparation course. Note: This course will run 2017-2018 and may be available in 2018-2019, depending on enrollment.

Guidance & Career Education

**GLS10,
Learning Strategies 1: Skills for Success In
Secondary School,
Grade 9, Open**

This course focuses on learning strategies to help students become better, more independent learners. Students will learn how to develop and apply literacy and numeracy skills, personal management skills, and interpersonal and teamwork skills to improve their learning and achievement in school, the workplace, and the community. The course helps students build confidence and motivation to pursue opportunities for success in secondary school and beyond. Registration for this course is through consultation with the Elementary panel and Secondary principal.

**GLC20, (0.5 Credit)
Career Studies,
Grade 10, Open**

This course teaches students how to develop and achieve personal goals for future learning, work, and community involvement. Students will assess their interests, skills, and characteristics and investigate current economic and workplace trends, work opportunities, and ways to search for work. The course explores postsecondary learning and career options, prepares students for managing work and life transitions, and helps students focus on their goals through the development of a career plan.

Health & Physical Education

**PPL1OFE,
Healthy Active Living Education,
Grade 9, Female, Open**

This course equips students with the knowledge and skills they need to make healthy choices now and lead healthy, active lives in the future. Through participation in a wide range of physical activities, students develop knowledge and skills related to movement competence and personal fitness that provide a foundation for active living. Students also acquire an understanding of the factors and skills that contribute to healthy development and learn how their own well-being is affected by, and affects, the world around them. Students build their sense of self, learn to interact positively with others, and develop their ability to think critically and creatively. This course is for females only.

**PPL1OMA,
Healthy Active Living Education,
Grade 9, Male, Open**

This course equips students with the knowledge and skills they need to make healthy choices now and lead healthy, active lives in the future. Through participation in a wide range of physical activities, students develop knowledge and skills related to movement competence and personal fitness that provide a foundation for active

living. Students also acquire an understanding of the factors and skills that contribute to healthy development and learn how their own well-being is affected by, and affects, the world around them. Students build their sense of self, learn to interact positively with others, and develop their ability to think critically and creatively. This course is for males only.

**PAF2OFE,
Healthy Living and Personal and
Fitness Activities,
Grade 10, Female, Open**

This course enables students to further develop the knowledge and skills they need to make healthy choices now and lead healthy, active lives in the future. Through participation in a wide range of physical activities, students develop knowledge and skills related to movement competence and personal fitness that provide a foundation for active living. Students also acquire an understanding of the factors and skills that contribute to healthy development and learn how their own well-being is affected by, and affects, the world around them. Students build their sense of self, learn to interact positively with others, and develop their ability to think critically and creatively. Activities will emphasize personal fitness activities including step and low impact aerobics, fitness walking, resistance training, aqua-fit, yoga and self-defense.

**PPL2OFE,
Healthy Active Living Education,
Grade 10, Female, Open**

This course enables students to further develop the knowledge and skills they need to make healthy choices now and lead healthy, active lives in the future. Through participation in a wide range of physical activities, students develop knowledge and skills related to movement competence and personal fitness that provide a foundation for active living. Students also acquire an understanding of the factors and skills that contribute to healthy development and learn how their own well-being is affected by, and affects, the world around them. Students build their sense of self, learn to interact positively with

others, and develop their ability to think critically and creatively.

**PPL2OMA,
Healthy Active Living Education,
Grade 10, Male, Open**

This course enables students to further develop the knowledge and skills they need to make healthy choices now and lead healthy, active lives in the future. Through participation in a wide range of physical activities, students develop knowledge and skills related to movement competence and personal fitness that provide a foundation for active living. Students also acquire an understanding of the factors and skills that contribute to healthy development and learn how their own well-being is affected by, and affects, the world around them. Students build their sense of self, learn to interact positively with others, and develop their ability to think critically and creatively.

**PAF3OFE,
Healthy Living and Personal and
Fitness Activities,
Grade 11, Female, Open**

This course enables students to further develop the knowledge and skills they need to make healthy choices now and lead healthy, active lives in the future. Through participation in a wide range of physical activities and exposure to a broader range of activity settings, students enhance their movement competence, personal fitness, and confidence. Students also acquire an understanding of the factors and skills that contribute to healthy development and learn how their own well-being is affected by, and affects, the world around them. Students build their sense of self, learn to interact positively with others, and develop their ability to think critically and creatively. Activities will emphasize personal fitness activities including step and low impact aerobics, fitness walking, resistance training, aqua-fit, yoga and self-defense.

**PPL3OFE,
Healthy Active Living Education,
Grade 11, Female, Open**

This course enables students to further develop

the knowledge and skills they need to make healthy choices now and lead healthy, active lives in the future. Through participation in a wide range of physical activities and exposure to a broader range of activity settings, students enhance their movement competence, personal fitness, and confidence. Students also acquire an understanding of the factors and skills that contribute to healthy development and learn how their own well-being is affected by, and affects, the world around them. Students build their sense of self, learn to interact positively with others, and develop their ability to think critically and creatively.

**PPL3OMA,
Healthy Active Living Education,
Grade 11, Male, Open**

This course enables students to further develop the knowledge and skills they need to make healthy choices now and lead healthy, active lives in the future. Through participation in a wide range of physical activities and exposure to a broader range of activity settings, students enhance their movement competence, personal fitness, and confidence. Students also acquire an understanding of the factors and skills that contribute to healthy development and learn how their own well-being is affected by, and affects, the world around them. Students build their sense of self, learn to interact positively with others, and develop their ability to think critically and creatively.

**PAL3O,
Healthy Living and Large-Group Activities,
Grade 11, Open**

This course enables students to further develop the knowledge and skills they need to make healthy choices now and lead healthy, active lives in the future. Through participation in a wide range of physical activities and exposure to a broader range of activity settings, students enhance their movement competence, personal fitness, and confidence. Students also acquire an understanding of the factors and skills that contribute to healthy development and learn how their own well-being is affected by, and

affects, the world around them. Students build their sense of self, learn to interact positively with others, and develop their ability to think critically and creatively. Students will work in a supportive and challenging environment as they strive to meet their individual fitness goals.

**PAL4O,
Large Group Activities,
Grade 12, Open**

This course enables students to further develop the knowledge and skills they need to make healthy choices. It places special emphasis on how students can maintain the habits of healthy, active living throughout their lives as they make the transition to adulthood and independent living. Through participation in a wide range of physical activities in a variety of settings, students can enhance their movement competence, personal fitness, and confidence. Students also acquire an understanding of the factors and skills that contribute to healthy development and learn how their own well-being is affected by, and affects, the world around them. Students build their sense of self, learn to interact positively with others, and develop their ability to think critically and creatively. This course is open to students of all abilities interested in advancing their fitness by identifying goals, creating an individualized training program while training and tracking their progress.

**PPL4OFE,
Healthy Active Living Education,
Grade 12, Female, Open**

This course enables students to further develop the knowledge and skills they need to make healthy choices. It places special emphasis on how students can maintain the habits of healthy, active living throughout their lives as they make the transition to adulthood and independent living. Through participation in a wide range of physical activities in a variety of settings, students can enhance their movement competence, personal fitness, and confidence. Students also acquire an understanding of the factors and skills that contribute to healthy development and learn

how their own well-being is affected by, and affects, the world around them. Students build their sense of self, learn to interact positively with others, and develop their ability to think critically and creatively.

**PPL4OMA,
Healthy Active Living Education,
Grade 12, Male, Open**

This course enables students to further develop the knowledge and skills they need to make healthy choices. It places special emphasis on how students can maintain the habits of healthy, active living throughout their lives as they make the transition to adulthood and independent living. Through participation in a wide range of physical activities in a variety of settings, students can enhance their movement competence, personal fitness, and confidence. Students also acquire an understanding of the factors and skills that contribute to healthy development and learn how their own well-being is affected by, and affects, the world around them. Students build their sense of self, learn to interact positively with others, and develop their ability to think critically and creatively.

**PSK4U,
Introductory Kinesiology,
Grade 12, University Preparation**

This course focuses on the study of human movement and of systems, factors, and principles involved in human development. Students will learn about the effects of physical activity on health and performance, the evolution of physical activity and sport, and the physiological, psychological, and social factors that influence an individual's participation in physical activity and sport. The course prepares students for university programs in physical education and health, kinesiology, health sciences, health studies, recreation, and sports administration. **Prerequisite: Any Grade 11 university or university/college preparation course in science, or any Grade 11 or 12 course in health and physical education**

Languages

French as a Second Language

**FSF1D,
Core French,
Grade 9, Academic**

This course provides opportunities for students to communicate and interact in French with increasing independence, with a focus on familiar topics related to their daily lives. Students will continue to develop language knowledge and skills by using language-learning strategies introduced in the elementary Core French program, and will apply creative and critical thinking skills in various ways. They will also enhance their understanding and appreciation of diverse French-speaking communities, and will develop the skills necessary to become life-long language learners. **Prerequisite: Minimum of 600 hours of elementary Core French instruction, or equivalent**

**FSF1P,
Core French,
Grade 9, Applied**

This course provides opportunities for students to communicate and interact in French in structured situations on everyday topics and to apply their knowledge of French in everyday situations. Students will continue to develop language knowledge and skills introduced in the elementary Core French program, through practical applications and concrete examples, and will use creative and critical thinking skills in various ways. They will also enhance their understanding and appreciation of diverse French-speaking communities, and will develop the skills necessary to become life-long language learners. **Prerequisite: Minimum of 600 hours of elementary Core French instruction, or equivalent**

**FSF2D,
Core French,
Grade 10, Academic**

This course provides opportunities for students to communicate in French about personally relevant, familiar, and academic topics in real-

life situations with increasing independence. Students will exchange information, ideas, and opinions with others in guided and increasingly spontaneous spoken interactions. Students will continue to develop their language knowledge and skills through the selective use of strategies that contribute to effective communication. They will also increase their understanding and appreciation of diverse French-speaking communities, and will continue to develop the skills necessary to become life-long language learners. **Prerequisite: FSF1D or FSF1P**

FSF3U,
Core French,
Grade 11, University Preparation

This course offers students extended opportunities to speak and interact in real-life situations in French with greater independence. Students will develop their creative and critical thinking skills through responding to and exploring a variety of oral and written texts. They will continue to broaden their understanding and appreciation of diverse French-speaking communities and to develop the skills necessary for life-long language learning. **Prerequisite: FSF2D**

FSF4U,
Core French,
Grade 12, University Preparation

This course provides extensive opportunities for students to speak and interact in French independently. Students will apply language-learning strategies in a wide variety of real-life situations, and will continue to develop their creative and critical thinking skills through responding to and interacting with a variety of oral and written texts. Students will also continue to enrich their understanding and appreciation of diverse French-speaking communities and to develop the skills necessary for life-long language learning. **Prerequisite: FSF3U**

International Languages

LWSBD,
Spanish,
Grade 10, Academic

This course enables students to develop competence in listening, speaking, reading, and writing in the language of study. Students will continue to participate in interactive activities in which they can apply and develop their language skills to communicate with native speakers of the language. They will explore aspects of culture in regions of the world where the language is spoken, including social customs, food, sports and leisure activities, popular festivals, and music. Although students will expand their vocabulary and knowledge of linguistic elements, the language they will use at this level will still be simple.

LWSCU,
Spanish,
Grade 11, University Preparation

This course offers students opportunities to further develop competence and confidence in listening, speaking, reading, and writing in the language of study. Students will participate in interactive activities (e.g., discussions about literature, travel, shopping) in which they will further develop their knowledge of linguistic elements. They will continue to explore aspects of culture in regions of the world where the language is spoken, including fashion, historical figures, art, and architecture. Students will enhance their critical and creative thinking skills through reading diverse materials, including original literature, and will explore a variety of personal and professional contexts in which knowledge of the international language is required. **Prerequisite: LWSBD**

LWSDU,
Spanish,
Grade 12, University Preparation

This course prepares students for postsecondary studies in the international language being studied. Students will continue to refine and enhance their listening, speaking,

reading, and writing skills in the language, with the goal of using these communication skills in a variety of personal, academic, and professional contexts. Using a wide variety of sources, including original texts in the language, students will consolidate their language skills as they use increasingly complex linguistic elements and language conventions. Students will also have opportunities to enrich their knowledge of aspects of culture in regions where the language is spoken, including issues related to popular culture, linguistic communities in Canada, literature, history, geography, and the arts. **Prerequisite: LWSCU**

Mathematics

MPM1D, Principles of Mathematics, Grade 9, Academic

This course enables students to develop understanding of mathematical concepts related to algebra, analytic geometry,

and measurement and geometry through investigation, the effective use of technology, and abstract reasoning. Students will investigate relationships, which they will then generalize as equations of lines, and will determine the connections between different representations of a relationship. They will also explore relationships that emerge from the measurement of three-dimensional objects and two-dimensional shapes. Students will reason mathematically and communicate their thinking as they solve multi-step problems.

MPM1DE, Principles of Mathematics, Grade 9, Academic, Enriched

This course enables students to develop understanding of mathematical concepts related to algebra, analytic geometry, and measurement and geometry through investigation, the effective use of technology, and abstract reasoning. Students will investigate relationships, which they will then generalize as equations

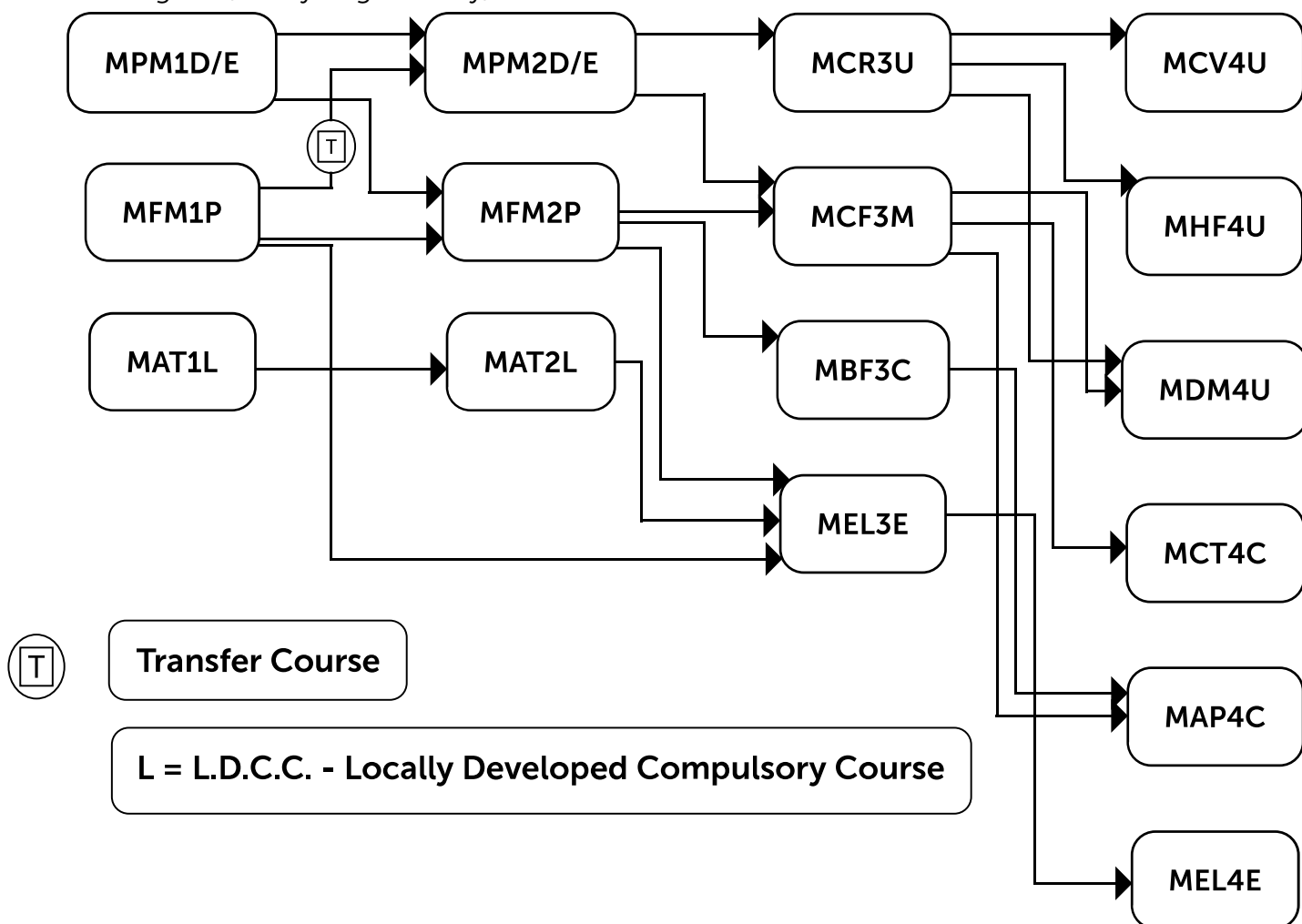

of lines, and will determine the connections between different representations of a relationship. They will also explore relationships that emerge from the measurement of three-dimensional objects and two-dimensional shapes. Students will reason mathematically and communicate their thinking as they solve multistep problems. This course also extends students' mathematical knowledge through enrichment that may include mathematics contest work, open-ended problems, techniques for solving non-routine problems or other topics of interest to the students.

**MAT1L,
Mathematics,
Grade 9, Locally Developed**

This course emphasizes further development of mathematical knowledge and skills to prepare students for success in their everyday lives, in the workplace and in the Grade 10 LDCC course. The course is organized in three strands related to money sense, measurement and proportional reasoning. In all strands, the focus is on developing and consolidating key foundational mathematical concepts and skills by solving authentic, everyday problems. Students have opportunities to further develop their mathematical literacy and problem-solving skills and to continue developing their skills in reading, writing and oral language through relevant and practical math activities. Registration for this course is through consultation with the Elementary panel.

**MFM1P,
Foundations of Mathematics,
Grade 9, Applied**

This course enables students to develop an understanding of mathematical concepts related to introductory algebra, proportional reasoning, and measurement and geometry through investigation, the effective use of technology, and hands-on activities. Students will investigate real-life examples to develop various representations of linear relations, and will determine the connections between the representations. They will also explore

certain relationships that emerge from the measurement of three-dimensional figures and two-dimensional shapes. Students will consolidate their mathematical skills as they solve problems and communicate their thinking. **Note: Students who wish to take Principles of Mathematics, Grade 10, Academic (MPM2D) after completing this course will need to take a transfer course.**

**MPM2D,
Principles of Mathematics,
Grade 10, Academic**

This course enables students to broaden their understanding of relationships and extend their problem-solving and algebraic skills through investigations, the effective use of technology, and abstract reasoning. Students will explore quadratic relations and their applications; solve and apply linear systems; verify properties of geometric figures using analytic geometry; and investigate the trigonometry of right and acute triangles. Students will reason mathematically and communicate their thinking as they solve multi-step problems. **Prerequisite: MPM1D or MPM1DE**

**MPM2DE,
Principles of Mathematics,
Grade 10, Academic, Enriched**

This course enables students to broaden their understanding of relationships and extend their problem-solving and algebraic skills through investigation, the effective use of technology, and abstract reasoning. Students will explore quadratic relationships and their applications; solve and apply linear systems; verify properties of geometric figures using analytic geometry; and investigate the trigonometry of right and acute triangles. Students will reason mathematically and communicate their thinking as they solve multi-step problems. This course also extends students' mathematical knowledge through enrichment that may include mathematics contest work, open-ended problems, techniques for solving non-routine problems or other topics of interest to the students. **Prerequisite: MPM1D or MPM1DE**

**MAT2L,
Mathematics,
Grade 10, Locally Developed**

This course emphasizes the extension of mathematical knowledge and skills to prepare students for success in their everyday lives, in the workplace, and in the Grade 11 Mathematics Workplace Preparation course. The course is organized in three strands related to money sense, measurement, and proportional reasoning. In all strands, the focus is on strengthening and extending key foundational mathematical concepts and skills by solving authentic, everyday problems. Students have opportunities to extend their mathematical literacy and problem-solving skills and to continue developing their skills in reading, writing, and oral language through relevant and practical math activities. **Prerequisite: MPM1D, MFM1P or MAT1L**

**MFM2P,
Foundations of Mathematics,
Grade 10, Applied**

This course enables students to consolidate their understanding of relationships and extend their problem-solving and algebraic skills through investigation, the effective use of technology, and hands-on activities. Students will develop and graph equations in analytic geometry; solve and apply linear systems, using real-life examples; and explore and interpret graphs of quadratic relations. Students will investigate similar triangles, the trigonometry of right triangles, and the measurement of three-dimensional figures. Students will consolidate their mathematical skills as they solve problems and communicate their thinking. **Prerequisite: MPM1D or MFM1P**

**MBF3C,
Foundations for College Mathematics,
Grade 11, College Preparation**

This course enables students to broaden their understanding of mathematics as a problem-solving tool in the real world. Students will extend their understanding of quadratic relations, as well as of measurement and geometry;

investigate situations involving exponential growth; solve problems involving compound interest; solve financial problems connected with vehicle ownership; and develop their ability to reason by collecting, analyzing, and evaluating data involving one and two variables. Students will consolidate their mathematical skills as they solve problems and communicate their thinking.

Prerequisite: MFM2P

**MCF3M,
Functions and Applications,
Grade 11, University/College Preparation**

This course introduces basic features of the function by extending students' experiences with the quadratic relations. It focuses on quadratic, trigonometric and exponential functions and their use in modeling real-world situations. Students will represent functions numerically, graphically, and algebraically; simplify expressions; solve equations; and solve problems relating to financial and trigonometric applications. Students will reason mathematically and communicate their thinking as they solve multi-step problems. **Prerequisite: MPM2D, MPM2DE or MFM2P**

**MCR3U,
Functions,
Grade 11, University Preparation**

This course introduces the mathematical concept of the function by extending students' experiences with linear and quadratic relations. Students will investigate properties of discrete and continuous functions, including trigonometric and exponential functions; represent functions numerically, algebraically, and graphically; solve problems involving applications of functions; and develop facility in simplifying polynomial and rational expressions. Students will reason mathematically and communicate their thinking as they solve multi-step problems. **Prerequisite: MPM2D or MPM2DE**

**MEL3E,
Mathematics for Work and Everyday Life,
Grade 11, Workplace Preparation**

This course enables students to broaden their understanding of mathematics as it is applied

in the workplace and daily life. Students will solve problems associated with earning money, paying taxes, and making purchases; apply calculations of simple and compound interest in saving, investing, and borrowing; and calculate the costs of transportation and travel in a variety of situations. Students will consolidate their mathematical skills as they solve problems and communicate their thinking. **Prerequisite: MPM1D, MFM1P or MAT2L**

MAP4C,
Foundations for College Mathematics,
Grade 12, College Preparation

This course enables students to broaden their understanding of real-world applications of mathematics. Students will analyze data using statistical methods; solve problems involving applications of geometry and trigonometry; simplify expressions; and solve equations. Students will reason mathematically and communicate their thinking as they solve multi-step problems. This course prepares students for college programs in areas such as business, health sciences, and human services, and for certain skilled trades. **Prerequisite: MBF3C or MCF3M**

MCT4C,
Mathematics for College Technology,
Grade 12, College Preparation

This course enables students to extend their knowledge of functions. Students will investigate and apply properties of polynomial, exponential, and trigonometric functions; continue to represent functions numerically, graphically, and algebraically; develop facility in simplifying expressions and solving equations; and solve problems that address applications of algebra, trigonometry, vectors, and geometry. Students will reason mathematically and communicate their thinking as they solve multi-step problems. This course prepares students for a variety of college technology programs. **Prerequisite: MCF3M or MCR3U**

MCV4U,
Calculus and Vectors,
Grade 12, University Preparation

This course builds on students' previous

experience with functions and their developing understanding of rates of change. Students will solve problems involving geometric and algebraic representations of vectors, and representations of lines and planes in three-dimensional space; broaden their understanding of rates of change to include the derivatives of polynomial, rational, exponential, and sinusoidal functions; and apply these concepts and skills to the modelling of realworld relationships. Students will also refine their use of the mathematical processes necessary for success in senior mathematics. This course is intended for students who plan to study mathematics in university and who may choose to pursue careers in fields such as physics and engineering. **Note: Advanced Functions (MHF4U) can be taken prior to (strongly recommended) or concurrently with Calculus and Vectors (MCV4U)**

MDM4U,
Mathematics of Data Management,
Grade 12, University Preparation

This course broadens students' understanding of mathematics as it relates to managing data. Students will apply methods for organizing large amounts of information; solve problems involving probability and statistics; and carry out a culminating project that integrates statistical concepts and skills. Students will also refine their use of the mathematical processes necessary for success in senior mathematics. Students planning to enter university programs in business, the social sciences, and the humanities will find this course of particular interest. **Prerequisite: MCF3M or MCR3U**

MEL4E,
Mathematics for Work and Everyday Life,
Grade 12, Workplace Preparation

This course enables students to broaden their understanding of mathematics as it is applied in the workplace and daily life. Students will investigate questions involving the use of statistics; apply the concept of probability to solve problems involving familiar situations; investigate accommodation costs and

create household budgets; use proportional reasoning; estimate and measure; and apply geometric concepts to create designs. Students will consolidate their mathematical skills as they solve problems and communicate their thinking. **Prerequisite: MEL3E**

MHF4U,
Advanced Functions,
Grade 12, University Preparation

This course extends students' experience with functions. Students will investigate the properties of polynomial, rational, logarithmic, and trigonometric functions; broaden their understanding of rates of change; and develop facility in applying these concepts and skills. Students will also refine their use of the mathematical processes necessary for success in senior mathematics. This course is intended both for students who plan to study mathematics in university and for those wishing to consolidate their understanding of mathematics before proceeding to any one of a variety of university programs. **Prerequisite: MCR3U or MCT4C**

Science

SNC1D,
Science,
Grade 9, Academic

This course enables students to develop their understanding of basic concepts in biology, chemistry, earth and space science, and physics, and to relate science to technology, society, and the environment. Throughout the course, students will develop their skills in the processes of scientific investigation. Students will acquire an understanding of scientific theories and conduct investigations related to sustainable ecosystems; atomic and molecular structures and the properties of elements and compounds; the study of the universe and its properties and components; and the principles of electricity.

SNC1DE,
Science,
Grade 9, Academic, Enriched

This course enables students to develop their understanding of basic concepts in biology, chemistry, earth and space science, and

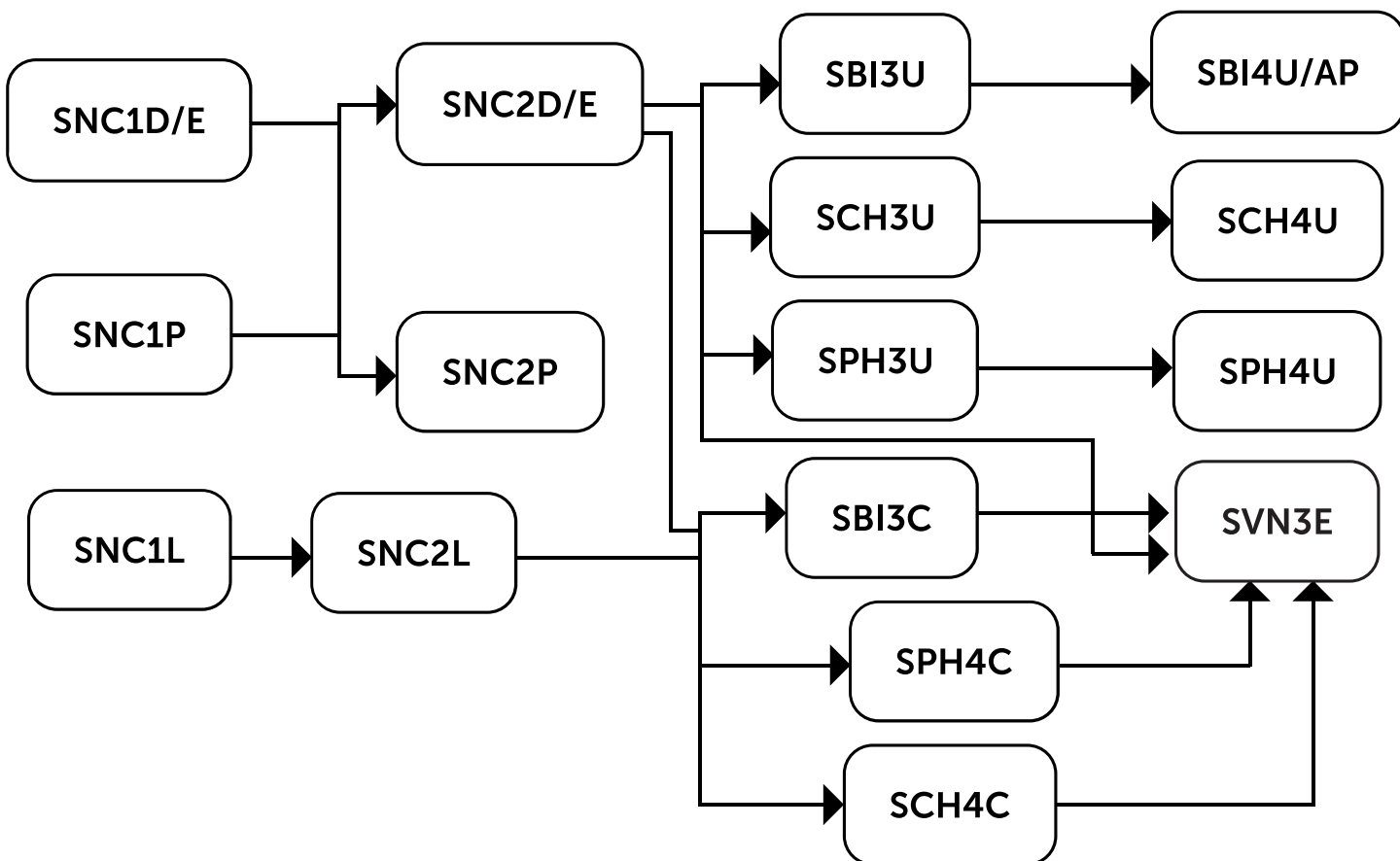

physics, and to relate science to technology, society, and the environment. Throughout the course, students will develop their skills in the processes of scientific investigation. Students will acquire an understanding of scientific theories and conduct investigations related to sustainable ecosystems; atomic and molecular structures and the properties of elements and compounds; the study of the universe and its properties and components; and the principles of electricity. The regular topics in SNC1D are supplemented and enriched by a number of related activities to delve into cause and effect scientific relationships as well as in-depth investigations that challenge students to investigate their own curiosity.

**SNC1L,
Science,
Grade 9, Locally Developed**

This course emphasizes reinforcing and strengthening science-related knowledge and skills, including scientific inquiry, critical thinking and the relationship between science, society, and the environment, to prepare students for success in everyday life, in the workplace and in the Science Grade 11 Workplace Preparation course. Students explore a range of topics including science in daily life, properties of common materials, life-sustaining processes in simple and complex organisms and electrical circuits. Students have the opportunity to extend mathematical and scientific process skills and to continue developing their skills in reading, writing and oral language through relevant and practical science activities.

**SNC1P,
Science,
Grade 9, Applied**

This course enables students to develop their understanding of basic concepts in biology, chemistry, earth and space science, and physics, and to apply their knowledge of science to everyday situations. They are also given opportunities to develop practical skills related to scientific investigation. Students will plan and conduct investigations into practical

problems and issues related to the impact of human activity on ecosystems; the structure and properties of elements and compounds; space exploration and the components of the universe; and static and current electricity.

**SNC2D,
Science,
Grade 10, Academic**

This course enables students to enhance their understanding of concepts in biology, chemistry, earth and space science, and physics, and of the interrelationships between science, technology, society, and the environment. Students are also given opportunities to further develop their scientific investigation skills. Students will plan and conduct investigations and develop their understanding of scientific theories related to the connections between cells and systems in animals and plants; chemical reactions, with a particular focus on acid-base reactions; forces that affect climate and climate change; and the interaction of light and matter. **Prerequisite: SNC1D or SNC1P. It is strongly recommended that SNC1P students have a recommendation from their teacher.**

**SNC2DE,
Science,
Grade 10, Academic, Enriched**

This course enables students to enhance their understanding of concepts in biology, chemistry, earth and space science, and physics, and of the interrelationships between science, technology, society, and the environment. Students are also given opportunities to further develop their scientific investigation skills. Students will plan and conduct investigations and develop their understanding of scientific theories related to the connections between cells and systems in animals and plants; chemical reactions, with a particular focus on acid-base reactions; forces that affect climate and climate change; and the interaction of light and matter. The regular topics in SNC2D are supplemented and enriched by a number of related activities to delve into cause and effect scientific relationships as well as in-

depth investigations that challenge students to investigate their own curiosity. **Prerequisite: SNC1DE or SNC1D**

**SNC2L,
Science,
Grade 10, Locally Developed**

This course emphasizes reinforcing and strengthening science-related knowledge and skills, including scientific inquiry, critical thinking, and the environmental impact of science and technology, to prepare students for success in everyday life, in the workplace, and in the Grade 11 Science Workplace Preparation course. Students explore a range of topics, including science in media, interactions of common materials, interdependence of organisms in communities, and using electrical energy. Students have the opportunity to extend mathematical and scientific process skills and to continue developing their skills in reading, writing, and oral language through relevant and practical science activities. **Prerequisite: SNC1L or SNC1P**

**SNC2P,
Science,
Grade 10, Applied**

This course enables students to develop a deeper understanding of concepts in biology, chemistry, earth and space science, and physics, and to apply their knowledge of science in real-world situations. Students are given opportunities to develop further practical skills in scientific investigation. Students will plan and conduct investigations into everyday problems and issues related to human cells and body systems; chemical reactions; factors affecting climate change; and the interaction of light and matter. **Prerequisite: SNC1D or SNC1P**

**SBI3C,
Biology,
Grade 11, College Preparation**

This course focuses on the processes that occur in biological systems. Students will learn concepts and theories as they conduct investigations in the areas of cellular biology, microbiology, genetics, the anatomy of mammals, and the structure of plants and their

role in the natural environment. Emphasis will be placed on the practical application of concepts, and on the skills needed for further study in various branches of the life sciences and related fields. **Prerequisite: SNC2D or SNC2P**

**SBI3U,
Biology,
Grade 11, University Preparation**

This course furthers students' understanding of the processes that occur in biological systems. Students will study theory and conduct investigations in the areas of biodiversity; evolution; genetic processes; the structure and function of animals; and the anatomy, growth, and function of plants. The course focuses on the theoretical aspects of the topics under study, and helps students refine skills related to scientific investigation. **Prerequisite: SNC2D or SNC2P**

**SCH3U,
Chemistry,
Grade 11, University Preparation**

This course enables students to deepen their understanding of chemistry through the study of the properties of chemicals and chemical bonds; chemical reactions and quantitative relationships in those reactions; solutions and solubility; and atmospheric chemistry and the behaviour of gases. Students will further develop their analytical skills and investigate the qualitative and quantitative properties of matter, as well as the impact of some common chemical reactions on society and the environment. It is recommended that students complete MPM2D before taking this course. **Prerequisite: SNC2D**

**SPH3U,
Physics,
Grade 11, University Preparation**

This course develops students' understanding of the basic concepts of physics. Students will explore kinematics, with an emphasis on linear motion; different kinds of forces; energy transformations; the properties of mechanical waves and sound; and electricity and magnetism. They will enhance their scientific investigation skills as they test laws of physics. In

addition, they will analyse the interrelationships between physics and technology, and consider the impact of technological applications of physics on society and the environment. It is recommended that students complete MPM2D before taking this course. **Prerequisite: SNC2D**

**SVN3E,
Environmental Science,
Grade 11, Workplace Preparation**

This course provides students with the fundamental knowledge of and skills relating to environmental science that will help them succeed in work and life after secondary school. Students will explore a range of topics, including the impact of human activities on the environment; human health and the environment; energy conservation; resource science and management; and safety and environmental responsibility in the workplace. Emphasis is placed on relevant, practical applications and current topics in environmental science, with attention to the refinement of students' literacy and mathematical literacy skills as well as the development of their scientific and environmental literacy **Prerequisite: Grade 9 Science, Academic or Applied, or a Grade 9 or 10 locally developed compulsory credit (LDCC) course in science**

**SBI4U,
Biology,
Grade 12, University Preparation**

This course provides students with the opportunity for in-depth study of the concepts and processes that occur in biological systems. Students will study theory and conduct investigations in the areas of biochemistry, metabolic processes, molecular genetics, homeostasis, and population dynamics. Emphasis will be placed on the achievement of detailed knowledge and the refinement of skills needed for further study in various branches of the life sciences and related fields. **Prerequisite: SBI3U**

**SBI4UAP,
Biology,
Grade 12, University Preparation,
Advanced Placement**

This course provides students with the opportunity for in-depth study of the concepts and processes that occur in biological systems. Students will study theory and conduct investigations in the areas of biochemistry, metabolic processes, molecular genetics, homeostasis, and population dynamics. Emphasis will be placed on the achievement of detailed knowledge and the refinement of skills needed for further study in various branches of the life sciences and related fields. In preparation for the AP Biology exam students will be given supplemental readings from Biology (9th Edition-- Campbell & Reece) and opportunities to work from the AP Biology lab manual. **Prerequisite: SBI3U**

**SCH4C,
Chemistry,
Grade 12, College Preparation**

This course enables students to develop an understanding of chemistry through the study of matter and qualitative analysis, organic chemistry, electrochemistry, chemical calculations, and chemistry as it relates to the quality of the environment. Students will use a variety of laboratory techniques, develop skills in data collection and scientific analysis, and communicate scientific information using appropriate terminology. Emphasis will be placed on the role of chemistry in daily life and the effects of technological applications and processes on society and the environment. **Prerequisite: SNC2D or SNC2P Note: This course is offered in alternating years; in, 2018 - 2019, 2020 - 2021**

**SCH4U,
Chemistry,
Grade 12, University Preparation**

This course enables students to deepen their understanding of chemistry through the study of organic chemistry, the structure and properties of matter, energy changes and rates

of reaction, equilibrium in chemical systems, and electrochemistry. Students will further develop their problemsolving and investigation skills as they investigate chemical processes, and will refine their ability to communicate scientific information. Emphasis will be placed on the importance of chemistry in everyday life and on evaluating the impact of chemical technology on the environment. **Prerequisite: SCH3U**

SPH4C,
Physics,
Grade 12, College Preparation

This course develops students' understanding of the basic concepts of physics. Students will explore these concepts with respect to motion; mechanical, electrical, electromagnetic, energy transformation, hydraulic, and pneumatic systems; and the operation of commonly used tools and machines. They will develop their scientific investigation skills as they test laws of physics and solve both assigned problems and those emerging from their investigations. Students will also consider the impact of technological applications of physics on society and the environment. **Prerequisite: SNC2D or SNC2P. Note: This course is offered in alternating years; 2017 - 2018, 2019 - 2020**

SPH4U,
Physics,
Grade 12, University Preparation

This course enables students to deepen their understanding of physics concepts and theories. Students will continue their exploration of energy transformations and the forces that affect motion, and will investigate electrical, gravitational, and magnetic fields and electromagnetic radiation. Students will also explore the wave nature of light, quantum mechanics, and special relativity. They will further develop their scientific investigation skills, learning, for example, how to analyze, qualitatively and quantitatively, data relating to a variety of physics concepts and principles. Students will also consider the impact of technological applications of physics on society and the environment. **Prerequisite: SPH3U**

Social Sciences & Humanities

HIF10,
Exploring Family Studies,
Grade 9, Open

This course explores, within the context of families, some of the fundamental challenges people face: how to meet basic needs, how to relate to others, how to manage resources, and how to become responsible members of society. Students will explore adolescent development and will have opportunities to develop interpersonal, decision-making, and practical skills related to daily life. They will learn about the diverse ways in which families function in Canada and will use research skills as they explore topics related to individual and family needs and resources.

HFN20,
Food and Nutrition,
Grade 10, Open

This course focuses on guidelines for making nutritious food choices. Students will investigate factors that influence food choices, including beliefs, attitudes, current trends, traditional eating patterns, food marketing strategies, and individual needs. Students will also explore the environmental impact of a variety of food choices at the local and global level. The course provides students with opportunities to develop food preparation skills and introduces them to the use of social science research methods in the area of food and nutrition.

HFC3E,
Food and Culture,
Grade 11, Workplace Preparation

This course focuses on the flavours, aromas, cooking techniques, foods, and cultural traditions of world cuisines. Students will demonstrate the ability to cook with ingredients and equipment from a range of cultures, describe food-related etiquette in a variety of countries and cultures, and explore ways in which Canadian food choices and traditions have been influenced by other cultures. Students will have opportunities to develop

practical skills and apply research skills as they investigate foods and food practices from around the world.

**HNC3C,
Understanding Fashion,
Grade 11, College Preparation**

This course introduces students to the world of fashion. Students will gain an understanding of theories related to fashion trends and of how culture, media, fashion cycles, retailing, and social and environmental factors influence fashion trends and consumer behaviour. Students will use various tools, technologies, and techniques safely and correctly to create fashion items. They will apply knowledge of fibres, fabrics, and the elements and principles of design when creating and assessing fashion-related products. Students will develop research skills as they investigate topics related to fashion.

**HPC3O,
Raising Healthy Children,
Grade 11, Open**

This course focuses on the skills and knowledge parents, guardians, and caregivers need, with particular emphasis on maternal health, pregnancy, birth, and the early years of human development (birth to six years old). Through study and practical experience, students will learn how to meet the developmental needs of young children, communicate with them, and effectively guide their early behaviour. Students will develop their research skills through investigations related to caregiving and child rearing.

**HSP3C,
Introduction to Anthropology,
Psychology, and Sociology,
Grade 11, College Preparation**

This course introduces students to theories, questions, and issues related to anthropology, psychology, and sociology. Students learn about approaches and research methods used by social scientists. They will be given opportunities to apply theories from a variety of perspectives, to conduct social science research, and to become familiar with current issues within the three disciplines.

**HSP3U,
Introduction to Anthropology,
Psychology, and Sociology,
Grade 11, University Preparation**

This course provides students with opportunities to think critically about theories, questions, and issues related to anthropology, psychology, and sociology. Students will develop an understanding of the approaches and research methods used by social scientists. They will be given opportunities to explore theories from a variety of perspectives, to conduct social science, and to become familiar with current thinking on a range of issues within the three disciplines. **Prerequisite: CHC2D or ENG2D**

**HFA4C,
Nutrition and Health,
Grade 12, College Preparation**

This course focuses on the relationship between nutrition and health at different stages of life and on global issues related to food production. Students will investigate the role of nutrition in health and disease and assess strategies for promoting food security and environmental responsibility. Students will learn about healthy eating, expand their repertoire of food-preparation techniques, and refine their ability to use social science research and inquiry methods to investigate topics related to nutrition and health. **Prerequisite: any Social Sciences and Humanities, English or Canadian and World Studies**

**HFA4U,
Nutrition and Health,
Grade 12, University Preparation**

This course examines the relationships between food, energy balance, and nutritional status; the nutritional needs of individuals at different stages of life; and the role of nutrition in health and disease. Students will evaluate nutrition-related trends and will determine how food choices can promote food security and environmental responsibility. Students will learn about healthy eating, expand their repertoire of food-preparation techniques, and develop their social science research skills

by investigating issues related to nutrition and health. **Prerequisite: any university, college or university/college preparation course in Social Sciences and Humanities, English or Canadian and World Studies, Food and Healthy Living, Grade 12 Workplace Preparation**

HFL4E,
Food and Healthy Living,
Grade 12, Workplace Preparation

This course focuses on the fundamental food needs of young adults. Students will learn how to stock a kitchen, make nutritious food choices, and accommodate the food needs of others. Through a range of practical experiences, they will develop skills needed in food preparation for personal use and for employment in the food industry. They will also learn about dining etiquette in different contexts and about responsible consumer practices. Students will use social science research methods to investigate issues related to food preparation and nutrition.

HHS4C,
Families in Canada,
Grade 12, College Preparation

This course enables students to develop an understanding of social science theories as they apply to individual development, the development of intimate relationships, and family and parent-child relationships. Students will explore a range of issues relating to the development of individuals and families in contemporary Canadian society as well as in other cultures and historical periods. They will develop the investigative skills required to conduct research on individuals, intimate relationships, and parent-child roles and relationships in Canada. **Prerequisite: any university, college or university/college preparation course in Social Sciences and Humanities, English or Canadian and World Studies, Food and Healthy Living, Grade 12 Workplace Preparation**

HHS4U,
Families in Canada,
Grade 12, University Preparation

This course enables students to draw on sociological, psychological, and anthropological theories and research to analyse the development of individuals, intimate relationships, and family and parent-child relationships. Students will focus on issues and challenges facing individuals and families in Canada's diverse society. They will develop analytical tools that enable them to assess various factors affecting families and to consider policies and practices intended to support families in Canada. They will develop the investigative skills required to conduct and communicate the results of research on individuals, intimate relationships, and parent-child relationships. **Prerequisite: any university or university/college preparation course in Social Sciences and Humanities, English or Canadian and World Studies**

HIP4O,
Personal Life Management,
Grade 12, Workplace Preparation

This course focuses on preparing students for living independently and working successfully with others. Students will learn to manage their personal resources to meet their basic needs for food, clothing, and housing. They will also learn about their personal, legal, and financial responsibilities and develop and apply interpersonal skills in order to make wise and responsible personal and occupational choices. Students will apply research and inquiry skills while investigating topics related to personal life management. The course emphasizes the achievement of expectations through practical experiences.

HSB4U,
Challenge and Change in Society,
Grade 12, University Preparation

This course focuses on the use of social science theories, perspectives, and methodologies to investigate and explain shifts in knowledge, attitudes, beliefs, and behaviour and their

impact on society. Students will critically analyse how and why cultural, social, and behavioural patterns change over time. They will explore the ideas of social theorists and use those ideas to analyse causes of and responses to challenges such as technological change, deviance, and global inequalities. Students will explore ways in which social science research methods can be used to study social change. **Prerequisite: any university or university/college preparation course in Social Sciences and Humanities, English or Canadian and World Studies**

Special Education

GLS10,
Learning Strategies: Skills for Success in Secondary School,
Grade 9, Open

This course focuses on learning strategies to help students become better, more independent learners. Students will learn how to develop and apply literacy and numeracy skills, personal management skills, and interpersonal and teamwork skills to improve their learning and achievement in school, the workplace, and the community. The course helps students build confidence and motivation to pursue opportunities for success in secondary school and beyond. Registration for this course is through consultation with the Elementary panel in conjunction with the Special Education Department at SCSS.

GLE20,
Learning Strategies:
Skills for Success in Secondary School,
Grade 10, Open

This course focuses on learning strategies to help students become better, more independent learners. Students will learn how to develop and apply literacy and numeracy skills, personal management skills, and interpersonal and teamwork skills to improve their learning and achievement in school, the workplace, and the community. The course helps students build confidence and motivation to pursue opportunities for success in secondary school

and beyond. Enrolment is through consultation with the Principal.

Technological Studies

Technological Education

Broad-Based Technological Education Course,
Broad-based technological education courses in Grades 10, 11, and 12 that lead to apprenticeship or certification programs or that are part of school- work transition programs may be planned for up to 330 hours of scheduled instructional time. This additional instructional time allows for the practice and refinement of skills needed to raise the quality of student's performance to the levels required for certification, entry into apprenticeship programs, or participation in school-work transition programs.

TIJ10,
Exploring Technologies,
Grade 9, Open

This course enables students to further explore and develop technological knowledge and skills introduced in the elementary science and technology program. Students will be given the opportunity to design and create products and/or provide services related to the various technological areas or industries, working with a variety of tools, equipment, and software commonly used in industry. Students will develop an awareness of environmental and societal issues, and will begin to explore secondary and postsecondary education and training pathways leading to careers in technology-related fields. **NEW: for 2017-2018 we will be offering a technology rotation consisting of 1/3 communication technology, 1/3 engineering and 1/3 construction technology.**

Communications Technology

TGJ20,
Communications Technology,
Grade 10, Open

This course introduces students to communications technology from a media

perspective. Students will work in the areas of TV/video and movie production, radio and audio production, print and graphic communications, photography, and animation. Student projects may include computer-based activities such as creating videos, editing photos, working with audio, cartooning, developing animations, and designing web pages. Students will also develop an awareness of environmental and societal issues related to communications technology and explore secondary and postsecondary education and training pathways and career opportunities in the various communications technology fields.

TGJ3M,
Communications Technology,
Grade 11, University/College Preparation

This course examines communications technology from a media perspective. Students will develop knowledge and skills as they design and produce media projects in the areas of live, recorded, and graphic communications. These areas may include TV, video, and movie production; radio and audio production; print and graphic communications; photography; digital imaging; broadcast journalism; and interactive new media. Students will also develop an awareness of related environmental and societal issues and explore college and university programs and career opportunities in the various communications technology fields.

Recommended preparation: TGJ2O

TGJ4M,
Communications Technology,
Grade 12, University/College Preparation

This course enables students to further develop media knowledge and skills while designing and producing projects in the areas of live, recorded, and graphic communications. Students may work in the areas of TV, video, and movie production; radio and audio production; print and graphic communications; photography; digital imaging; broadcast journalism; and interactive new media. Students will also expand their awareness of environmental and societal issues related to communications technology and will investigate

career opportunities and challenges in a rapidly changing technological environment.

Emphasis Courses Related to TGJ3M

TGI3M,
Communications Technology,
Interactive New Media and Animation,
Grade 11, University/College Preparation

This course enables students to further develop knowledge and skills in animation, and advanced graphic creation and manipulation.

Prerequisite: TGJ3M or TGJ3MT

TGP3M,
Communications Technology,
Photography and Digital Imaging,
Grade 11, University/College Preparation

This course enables students to further develop knowledge and skills in digital imaging and photography. **Prerequisite: TGJ3M or TGJ3MT**

TGP3MZ, Dual Credit (pending approval)
Communications Technology,
Photography and Digital Imaging,
Grade 11, University/College Preparation

This course enables students to further develop knowledge and skills in digital imaging and photography. **Prerequisite: TGJ3M or TGJ3MT. This course will be partially team-taught with a college instructor. Upon successful completion of the college portion of the secondary course, the student will be eligible to receive a college credit (pending approval).**

TGR3M,
Communications Technology,
Radio, Audio and Sound Production,
Grade 11, University/College Preparation

This course enables students to further develop knowledge and skills in radio, audio and recorded sound production. **Prerequisite: TGJ3M or TGJ3MT**

**TGV3M,
Communications Technology,
Movie and Video Production,
Grade 11, University/College Preparation**

This course enables students to further develop knowledge and skills in video and film production. **Prerequisite: TGJ3M or TGJ3MT**

**TGJ3O,
Communications Technology, Broadcast and
Print Production,
Grade 11, Open**

This course enables students to develop knowledge and skills in the areas of graphic communication, printing and publishing, audio and video production, and broadcast journalism. Students will work both independently and as part of a production team to design and produce media products in a project driven environment. Practical projects may include the making of signs, yearbooks, video and/or audio productions, newscasts, and documentaries. Students will also develop an awareness of related environmental and societal issues and explore secondary and postsecondary education and training pathways and career opportunities in the various communications technology fields. **Recommended preparation: TGJ2O**

Emphasis Courses Related to TGJ4M

**TGI4M,
Communications Technology,
Interactive New Media and Animation,
Grade 12, University/College Preparation**

This course enables students to further develop knowledge and skills in animation, and advanced graphic creation and manipulation. **Prerequisite: TGJ4M or TGJ4MT or TGI3M**

**TGP4M,
Communications Technology,
Photography and Digital Imaging,
Grade 12, University/College Preparation**

This course enables students to further develop knowledge and skills in digital imaging and photography. **Prerequisite: TGJ4M or TGJ4MT**

or TGP3M

**TGP4MZ, Dual Credit (pending approval)
Communications Technology,
Photography and Digital Imaging,
Grade 12, University/College Preparation**

This course enables students to further develop knowledge and skills in digital imaging and photography. **Prerequisite: TGJ4M or TGJ4MT or TGP3M** This course will be partially team-taught with a college instructor. Upon successful completion of the college portion of the secondary course, the student will be eligible to receive a college credit (pending approval).

**TGR4M,
Communications Technology,
Radio, Audio and Sound Production,
Grade 12, University/College Preparation**

This course enables students to further develop knowledge and skills in radio, audio and recorded sound production. **Prerequisite: TGJ4M or TGJ4MT or TGR3M**

**TGV4M,
Communications Technology,
Movie and Video Production,
Grade 12, University/College Preparation**

This course enables students to further develop knowledge and skills in video and film production. **Prerequisite: TGJ4M or TGJ4MT or TGV3M**

Computer Technology

**TEJ2O,
Computer Technology,
Grade 10, Open**

This course introduces students to computer systems, networking, and interfacing, as well as electronics and robotics. Students will assemble, repair, and configure computers with various types of operating systems and application software. Students will build small electronic circuits and write computer programs to control simple peripheral devices or robots. Students will also develop an awareness of related environmental and societal issues, and will learn about secondary and postsecondary pathways and career opportunities in computer technology

**TEC3E,
Computer Technology,
Grade 11, Workplace Preparation**

This course enables students to further develop knowledge and skills related to computer hardware. The focus of this course is a practical hands-on approach to proper maintenance and repair of desktop and laptop computers. Students will gain a better understanding of operating systems and proper software installation practices. **Prerequisite: None**

**TEJ3M,
Computer Engineering Technology,
Grade 11, University/College Preparation**

This course examines computer systems and control of external devices. Students will assemble computers and small networks by installing and configuring appropriate hardware and software. Students will develop knowledge and skills in electronics, robotics, programming, and networks, and will build systems that use computer programs and interfaces to control and/or respond to external devices. Students will develop an awareness of related environmental and societal issues, and will learn about college and university programs leading to careers in computer technology.

Recommended Preparation: TEJ2O

**TEJ4M,
Computer Engineering Technology,
Grade 12, University/College Preparation**

This course extends students' understanding of computer systems and computer interfacing with external devices. Students will assemble computer systems by installing and configuring appropriate hardware and software, and will learn more about fundamental concepts of electronics, robotics, programming, and networks. Students will examine related environmental and societal issues, and will explore postsecondary pathways leading to careers in computer technology.

Prerequisite: TEJ3M

Construction Technology

**TCJ2O,
Construction Technology,
Grade 10, Open**

This course introduces students to building materials and processes through opportunities to design and build various construction projects. Students will learn to create and read working drawings; become familiar with common construction materials, components, and processes; and perform a variety of fabrication, assembly, and finishing operations. They will use a variety of hand and power tools and apply knowledge of imperial and metric systems of measurement, as appropriate. Students will develop an awareness of environmental and societal issues related to construction technology, and will explore secondary and postsecondary pathways leading to careers in the industry. **Recommended preparation: TIJ1O or TTI1O**

**TCJ3C,
Construction Engineering Technology,
Grade 11, University/College Preparation**

This course focuses on the development of knowledge and skills related to residential construction. Students will gain hands-on experience using a variety of construction materials, processes, tools, and equipment; learn about building design and planning construction projects; create and interpret working drawings and sections; and learn how the Ontario Building Code and other regulations and standards apply to construction projects. Students will also develop an awareness of environmental and societal issues related to construction technology, and will explore career opportunities in the field. **Recommended Prerequisites: TCJ2O, TIJ1O or TTI1O**

**TCJ4C,
Construction Engineering Technology,
Grade 12, University/College Preparation**

This course enables students to further develop knowledge and skills related to residential construction and to explore light

commercial construction. Students will gain hands-on experience using a variety of materials, processes, tools, and equipment, and will learn more about building design and project planning. They will continue to create and interpret construction drawings and will extend their knowledge of construction terminology and of relevant building codes and regulations, as well as health and safety standards and practices. Students will also focus on environmental and societal issues related to construction engineering technology, and will explore career opportunities in the field.

Prerequisite: TCJ3C

Manufacturing Technology

TMJ2O,
Manufacturing Technology,
Grade 10, Open

This course introduces students to the manufacturing industry by giving them an opportunity to design and fabricate products using a variety of processes, tools, and equipment. Students will learn about technical drawing, properties and preparation of materials, and manufacturing techniques. Student projects may include a robotic challenge, a design challenge, or a fabrication project involving processes such as machining, welding, vacuum forming, or injection moulding. Students will develop an awareness of environmental and societal issues related to manufacturing and will learn about secondary and postsecondary pathways leading to careers in the industry. **Recommended preparation:** TIJ1O or TTI1O

TMJ3C,
Manufacturing Technology,
Grade 11, College Preparation

This course enables students to develop knowledge and skills through hands-on, project-based learning. Students will acquire design, fabrication, and problem-solving skills while using tools and equipment such as lathes, mills, welders, computer aided machines, robots, and control systems. Students may

have opportunities to obtain industry-standard certification and training. Students will develop an awareness of environmental and societal issues related to manufacturing and will learn about pathways leading to careers in the industry. **Recommended preparation:** TMJ2O, TCJ2O, TIJ1O or TTI1O

TMJ4C,
Manufacturing Technology,
Grade 12, College Preparation

This course enables students to further develop knowledge and skills related to machining, welding, print reading, computer numerical control (CNC), robotics, and design. Students will develop proficiency in using mechanical, pneumatic, electronic, and computer control systems in a project-based learning environment and may have opportunities to obtain industry-standard training and certification. Students will expand their awareness of environmental and societal issues and career opportunities in the manufacturing industry. **Prerequisite:** TMJ3C

TGJ3MT,
Communications Technology Live Technical
Production,
Grade 11, University/College Preparation

This course examines communications technology from a media perspective. Students will develop knowledge and skills as they design and produce media projects in the areas of live, recorded, and graphic communications. These areas may include TV, video, and movie production; radio and audio production; print and graphic communications; photography; digital imaging; broadcast journalism; and interactive new media. Students will also develop an awareness of related environmental and societal issues and explore college and university programs and career opportunities in the various communications technology fields. Working in groups, students will provide leadership and technical skills required to produce Television/Web content for both school and community based programming.

Recommended preparation: TGJ2O or TGJ2OT

**TGJ3OT,
Communications Technology,
Live Technical Production,
Grade 11, Open**

This course enables students to develop knowledge and skills in the areas of graphic communication, printing and publishing, audio and video production, and broadcast journalism. Students will work both independently and as part of a production team to design and produce media products in a project driven environment. Practical projects may include the making of signs, yearbooks, video and/or audio productions, newscasts, and documentaries. Students will also develop an awareness of related environmental and societal issues and explore secondary and postsecondary education and training pathways and career opportunities in the various communications technology fields. Working in groups, students will provide leadership and technical skills required to produce Television/Web content for both school and community based programming.

Recommended preparation: TGJ2O or TGJ2OT

**TGJ4MT,
Communications Technology,
Live Technical Productions,
Grade 12, University/College Preparation**

This course enables students to further develop media knowledge and skills while designing and producing projects in the areas of live, recorded, and graphic communications. Students may work in the areas of TV, video, and movie production; radio and audio production; print and graphic communications; photography; digital imaging; broadcast journalism; and interactive new media. Students will also expand their awareness of environmental and societal issues related to communications technology and will investigate career opportunities and challenges in a rapidly changing technological environment. Working in groups, students will provide leadership and technical skills required to produce Television/Web content for both school and community based programming.

Prerequisite: TGJ3M or TGJ3MT

Apprenticeship Pathway

Nicholas Binet



Nicholas Binet moved to Stratford in October of his grade 9 year. As a new student to the city and school, he was nervous but quickly realized that the students and teachers at Stratford Central were friendly and inclusive. His transfer to Central was seamless; he made friends and found classes that he enjoyed. In Grade 10, Nicholas took his first food and nutrition course (HFN20). He didn't know what to expect but was pleasantly surprised by the course content and passion for cooking that he didn't even know he had. Nicholas will always remember his teacher, Mr. Wilson, as one of his favorite teachers and definitely his most influential. Mr. Wilson quickly noticed Nicholas' passion and was even able to give him his first knife kit.

Since then, Nicholas has included cooking into his timetable as much as possible. In order to do this, he selected our Grade 11 Food & Culture course (HFC3E) and Grade 12 Food & Nutrition class (HFA4C). In addition, he took advantage of some of Stratford Central's alternative programming including Cooperative Education where he worked as a prep cook at a local restaurant. He also participated in the Dual Credit Program offered by Conestoga College. Here, he was enrolled in Kitchen: Part 1 where he earned two credits. He followed up by taking Kitchen: Part 2 - Advanced. He really enjoyed this experience and learned some valuable skills that he will be able to use in the future.

Next semester, Nicholas is looking forward to his concurrent education experience at Northwestern SS. He will remain a student at Stratford Central in the morning and will take a bus to SNSS at lunch time in order to take advantage of some of the specialized programming offered there. When Nicholas graduates from Stratford Central in June, he looks forward to beginning his apprenticeship.

College Pathway

Taylor Greene



Taylor Greene has attended Stratford Central since Grade 7. Throughout all 6 years she has been a part of the music department. Mr. Pepper, Mr. Gilbert, and Mrs. Ortelli have all had a huge impact on her high school experience and made the music department feel like family. Not only was being a member of Symphonic Band fun, it also earned Taylor an extra 1.5 high school credits, allowing her to take a spare she wouldn't have otherwise been able to have.

In addition to her passion for music, taking math and science as electives all through high school have given Taylor unique learning opportunities including the annual biology field trip to the Human Anatomy Lab. This has fuelled her passion for medicine and animal science and helped her to envision her future after high school. Until her last year of school, Taylor was unsure if she would go to university or college and so during her 4 years in secondary she included both "U" and "C" courses in her timetable. Blending the two pathways has enabled her to pursue a competitive college program. She will also have the option to bridge to University for veterinary school after she obtains her diploma if she so chooses. The future is bright for Taylor and she is excited about the possibilities that it holds.

University Pathway

Wah He



Wah He was born and raised in China. For years, she envisioned herself studying abroad, and kept dreaming that she might one day stand in a foreign country and speak perfect English. After years of careful consideration, her parents decided to send her to Canada and selected Stratford Central as the ideal school for her to attend. Wah has been here since the fall of 2015. When she first arrived she said, "It was confusing; everything was totally different." She was comforted when everyone was very approachable. "From the ESL teacher to the office secretary, so many people were great to me!" Wah said. In general, she thinks the educational system is better here because

you aren't forced to take courses that you aren't interested in and this has made her life better. She misses her family but knows that she made the right decision.

Math classes have been Wah's favorite to attend. Her teachers are funny and engaging, making the course enjoyable. In her spare time she plays on the badminton and basketball team. Even though she finds the training very intense and challenging, she is still glad that she went out for the team this year. "It made my final year of high school truly awesome!" Most importantly, being on the teams has allowed her to build friendships with other students from Stratford Central. She said it was also easy to make friends with all of the other international students. Everyone was in the same situation and they all support each other.

Since she has enjoyed her time here so much, Wah plans to stay in Canada and her parents support her decision. In the future, Wah plans to attend university for business studies. In particular, her dream is to attend University of Toronto and so she is working hard to achieve that goal.

Workplace Pathway

Nick Tigani



Nick Tigani will be graduating from Stratford Central in June of 2017 and over the past 4 years he has explored several career paths including carpentry and mechanics. Nick says he was never the type of student who excelled in academics but he didn't mind coming to school everyday because he was excited to spend time in the woodshop with Mr. Hombach. He preferred hands-on courses that gave him practical working knowledge that he could use in everyday life. Nick says his most influential teacher was his grade 10 math teacher Mr. Steel because, "He always gave good advice and always had time to talk."

In grade 11, Nick was excited to attend school everyday when he was enrolled in the Cooperative Education program as a general labourer with Feltz Design & Build. Nick said the workplace was a lot different than school. "There were different expectations, you're always busy, always accountable and you always have to do your best work." The dual credit program at Lambton College gave him some hands-on experience in the fields of welding and electrical, in addition to some college and high school credits. Nick considered attending college for carpentry and framing but he has decided to head directly into the workforce in order to improve his skills on the job site.